

ADLEEPOWER®

BM 601A

Voltage	Rate Torque	Rate Power	Rate Speed	Rate Current
48V	6.8kg-cm	600W	8600Rpm	18A
	Max. Torque	Max. Power	Max. Speed	Max. Current
	52kg-cm	2400W	9000RPM	85A

Power Supply: Lead acid battery

ADLEE POWERTRONIC CO., LTD.

Tel: 886-4-25622651

Fax: 886-4-25628289

Web: www.adlee.com

E-mail: webmaster@adlee.com

T/N curve

ADLEEPOWER®

■ BM 601 A
Torque

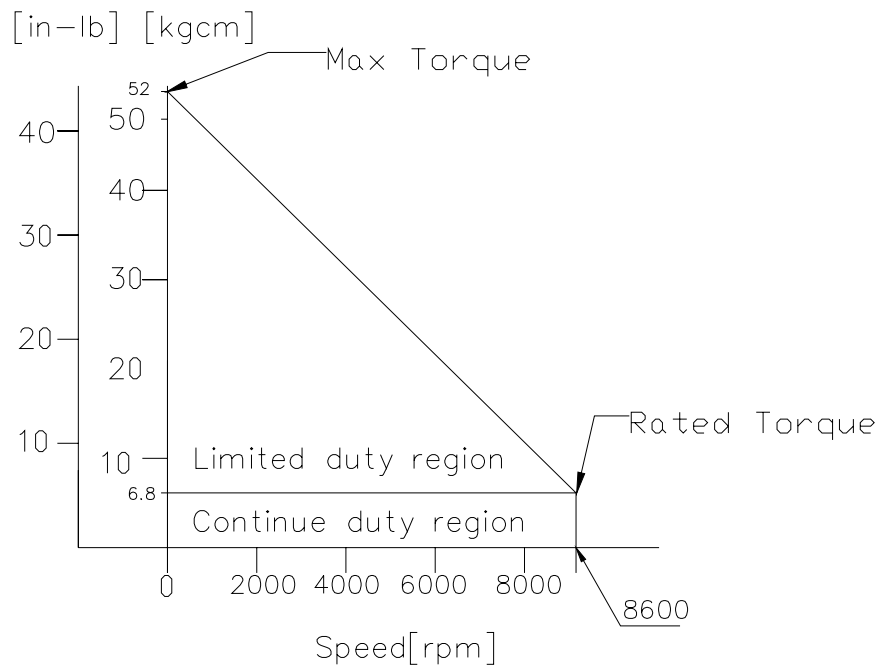

1 Nm = 10.2 kg-cm
1 in-lb = 16 in-oz
1 kg-cm = 0.866 lb-in

Control signal diagram

ADLEEPOWER®

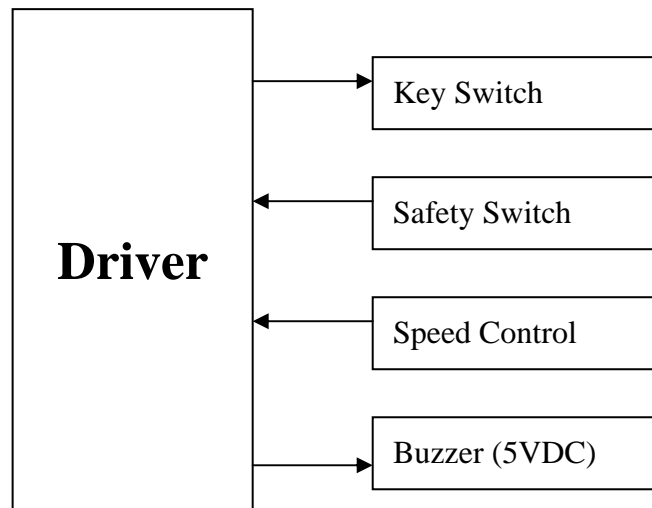

Protection

- Over current protection
- Motor over heat protection
- Driver over heat protection
- Motor phase to phase short circuit protection
- Low voltage protection
- Accelerator initial detection
- Battery Protection: Motor stop running if battery voltage is lower than 40.5VDC for 6 seconds.

Buzzer Signal

ADLEEPOWER®

	Function	Active condition	Buzzer signal
1	Battery reaching low power condition	Battery voltage is lower than 44.5VDC for 2 seconds.	Output 6 short alarms,
2	Motor standby	Key switch on	Output 1 long alarm, and follow with 3 short alarms
3	Overtime in standby mode	Motor standby more than 10 minutes	3 short alarms per second

Buzzer voltage: 5VDC

Note :

1. This is telling driver, battery will be out of energy very soon. They need to charge batteries ASAP.
2. This is telling driver, vehicle is standby and can be run after pushing the pedal.
3. This is telling driver, the motor is standby for more than 10 minutes. For safety reason, driver should switch off the key switch.

Driver Dimension

ADLEEPOWER®

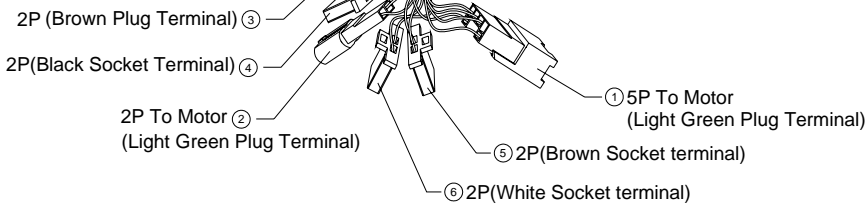
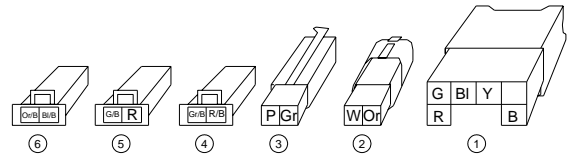
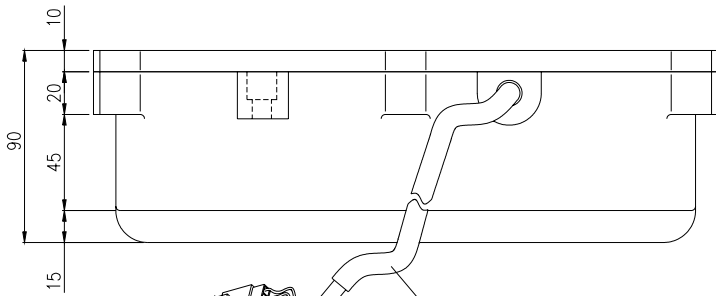
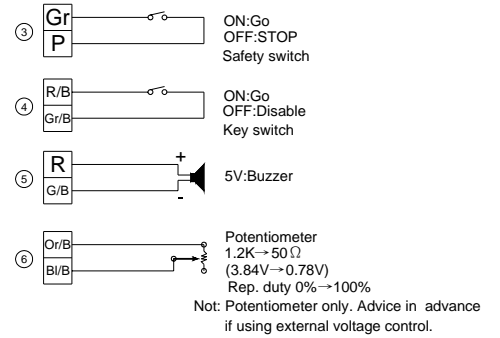
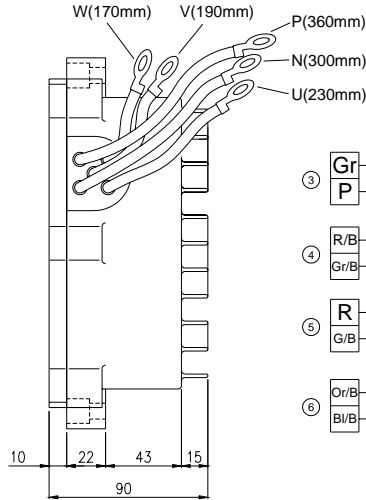
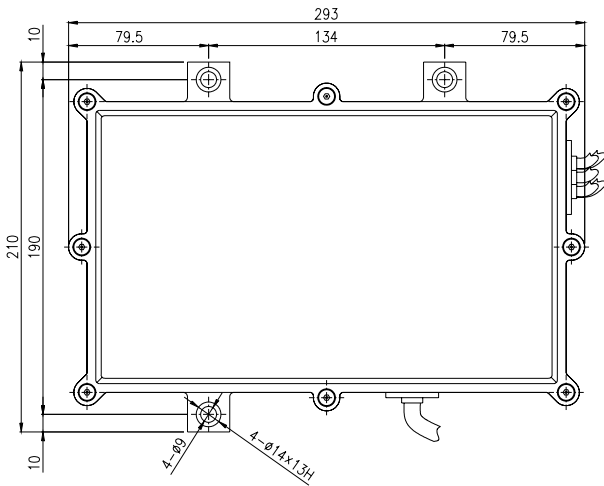

Note: A clutch is recommended to be installed with the motor.

- Color
- B:Black
 - G:Green
 - W:White
 - Br:Brown
 - Y:Yellow
 - R:Red
 - Gr:Gray
 - Gr/B:Gray/Black
 - Bl:Blue
 - Or:Orange
 - P:Purple