

ADLEEPOWER®

BM 1000A

Voltage	Rate Torque	Rate Power	Rate Speed	Rate Current
48V	11.7kg-cm	1000W	8300Rpm	26A
	Max. Torque	Max. Power	Max. Speed	Max. Current
	60kg-cm	2800W	9000RPM	95A

Power Supply: Lead acid battery

ADLEE POWERTRONIC CO., LTD.

Tel: 886-4-25622651

Fax: 886-4-25628289

Web: www.adlee.com

E-mail: webmaster@adlee.com

T/N curve

ADLEEPOWER®

■ BM 1000A 48V
Torque

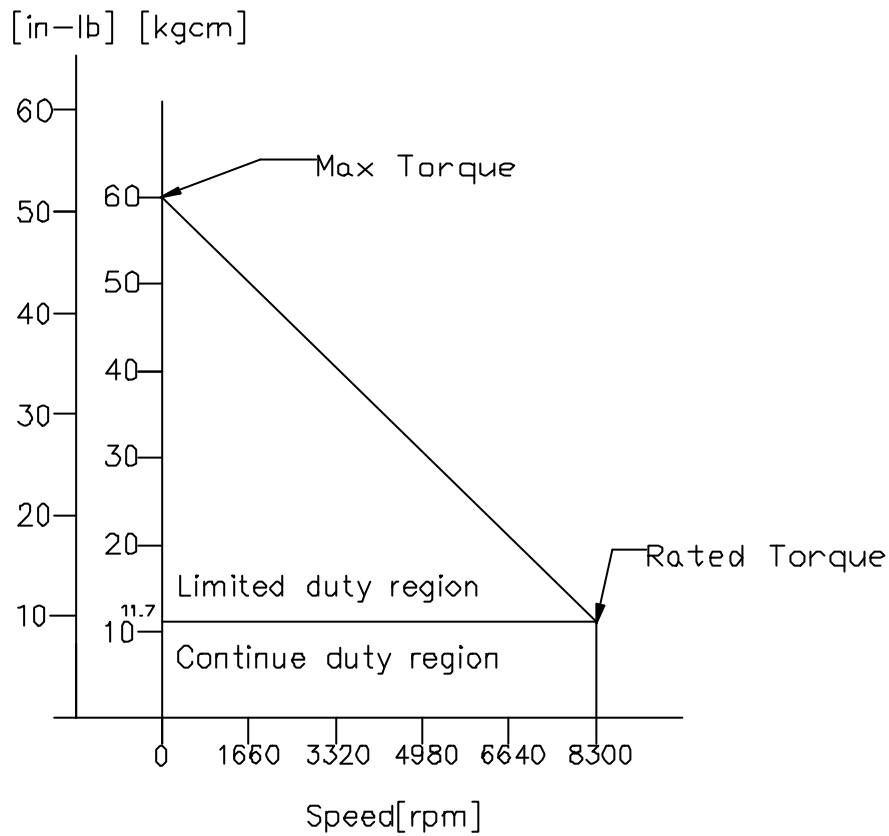

1 Nm = 10.2 kg-cm
1 in-lb = 16 in-oz
1 kg-cm = 0.866 lb-in

Control signal diagram

ADLEEPOWER®

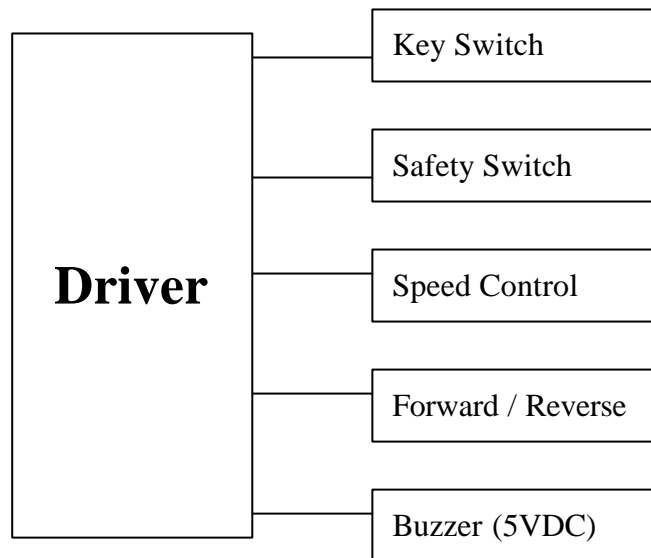

Protection

- Over current protection
- Motor over heat protection
- Driver over heat protection
- Motor phase to phase short circuit protection
- Low voltage protection
- Accelerator initial detection
- Battery Protection: Motor stop running if battery voltage is lower than 40.5VDC for 6 seconds.

Buzzer Signal

ADLEEPOWER®

	Function	Active condition	Buzzer signal
1	Battery reaching low power condition	Battery voltage is lower than 44.5VDC for 2 seconds.	Output 6 short alarms,
2	Motor standby	Key switch on	Output 1 long alarm, and follow with 3 short alarms
3	Overtime in standby mode	Motor standby more than 10 minutes	3 short alarms per second
4	Motor reverse operation	CCW is active	1 short alarm per second

Buzzer voltage: 5VDC

Note :

1. This is telling driver, battery will be out of energy very soon. They need to charge batteries ASAP.
2. This is telling driver, vehicle is standby and can be run after pushing the pedal.
3. This is telling driver, the motor is standby for more than 10 minutes. For safety reason, driver should switch off the key switch.
4. This alarm can tell everyone the vehicle is going to back drive

Motor Dimension

ADLEEPOWER®

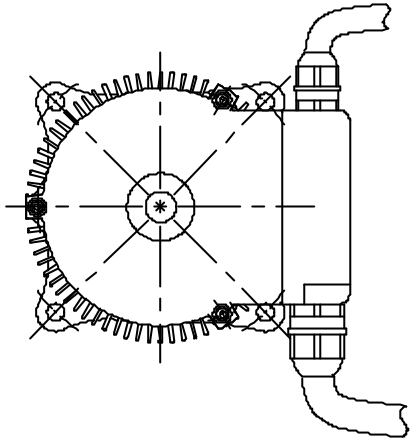

Wire length: 15cm

Unit: mm(inch)

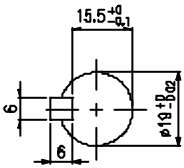
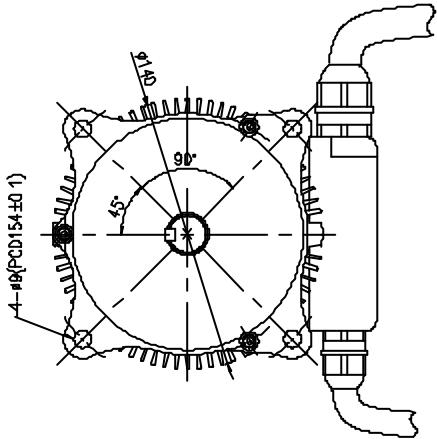
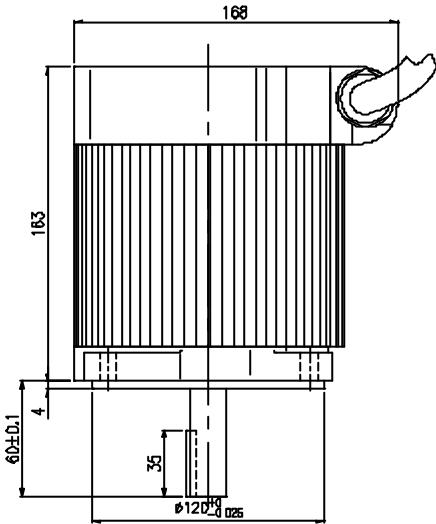

Driver Dimension

ADLEEPOWER®

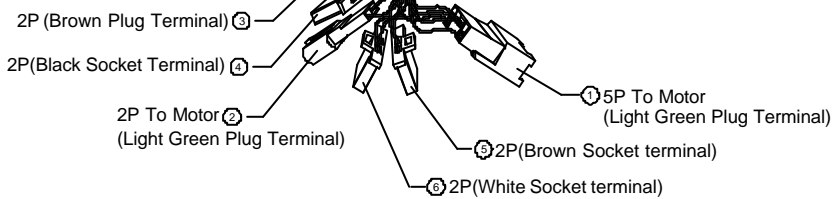
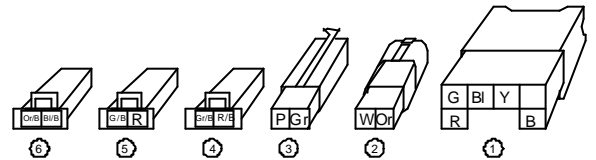
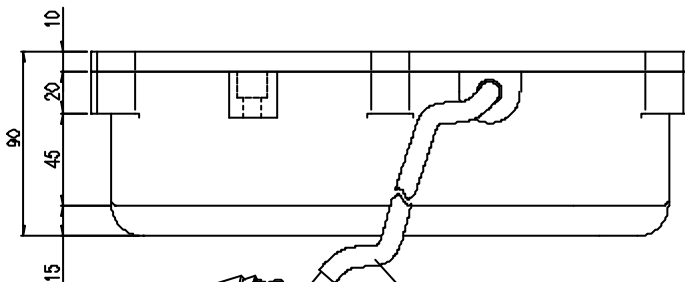
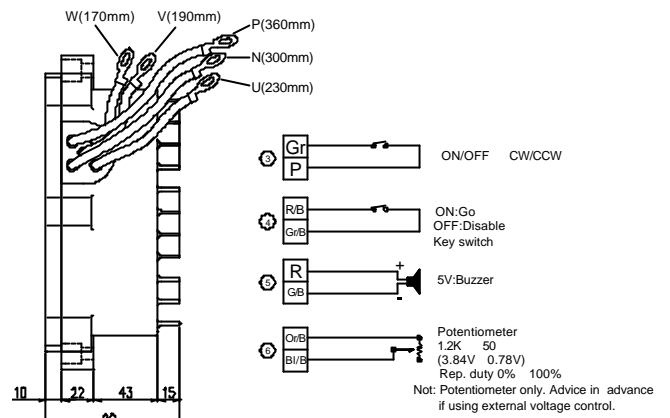
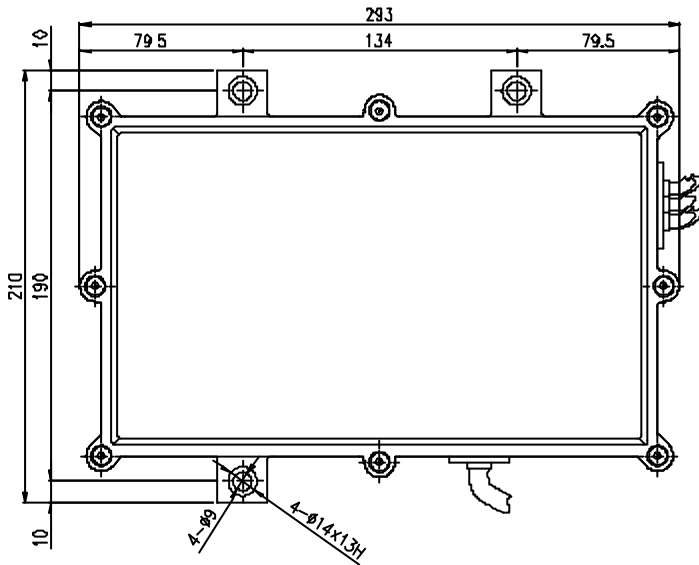

Color

- B:Black
- G:Green
- W:White
- Br:Brown
- Y:Yellow
- R:Red
- Gr:Gray
- Gr/B:Gray/Black
- Bl:Blue
- Or:Orange
- P:Purple

Note: A clutch is recommended to be installed with the motor.