

# INSTRUCTION MANUAL

## GENERAL-PURPOSE INVERTER



THANK YOU VERY MUCH FOR YOUR PURCHASE  
OF ADLEE INVERTER AS SERIES.  
PLEASE READ THIS INSTRUCTION MANUAL  
BEFORE INSTALLATION OF THE INVERTER.

## PREFACE

This general-purpose inverter made by ADLEE Powertronic., Ltd. Read this instruction manual thoroughly before operation.

This manual will be helpful in the installation, parameter setting, troubleshooting, and daily maintenance of the AC motor drives. To guarantee safe operation of the equipment, read the following safety guidelines before connecting power to the AC drives. Keep this operating manual handy and distribute to all users for reference.

### A. General Precaution

1. There are some covers and shields on this inverter.  
Make sure all covers and shields are replaced before operating this product.
2. This manual may be modified when necessary because of improvement of the product or changes in specification.
3. Contact your ADLEE representative to order a copy of this manual, if your manual has been damaged or lost.
4. ADLEE is not responsible for any modification of the product made by the user, since that will void your guarantee.

### B. Safety symbols

Symbols which may appear on the manual

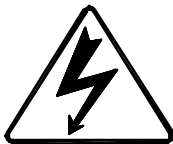

#### **WARNING**

Indicates a potentially hazardous situation which, if not avoided, could result in death or serious injury to personnel.



#### **CAUTION**

Indicates a potentially hazardous situation which, if not avoided, may result in minor or moderate injury to personnel and damage to equipment.

---

## RECEIVING

---

### CAUTION

- \* Do not install or operate the driver which is damaged or has missing parts.  
Failure to observe this caution may result in personal injury or equipment damage.
- 

## INSTALLATION

---



### CAUTION

- \* Lift the cabinet by the base. When moving the unit, never lift by the front cover.  
Otherwise, the main unit may be dropped causing damage to the unit.
  - \* Mount the driver on nonflammable material. (i.e. metal)  
Failure to observe this caution can result a fire.
  - \* When mounting units in an enclosure, install a fan or other cooling device to keep the intake air temperature below 45 °C.  
Overheating may cause a fire or damage to the unit.
- 

## INSTALLATION

---

### WARNING

- \* Only commence wiring after verifying that the power supply is turned OFF.  
Failure to observe this warning can result in an electrical shock or a fire.
- \* Wiring should be performed only by qualified personnel.  
Failure to observe this warning can result in an electrical shock or a fire.
- \* Make sure to ground the ground terminal.  
Ground resistance : 100 Ohm or less.  
Failure to observe this warning can result in an electrical shock or a fire.

## CAUTION

- \* Verify that the driver rated voltage coincides with the AC power supply voltage.  
Failure to observe this caution can result in personal injury or a fire.
- \* Do not perform a withstand voltage test of the driver.  
It may cause semi-conductor elements to be damaged.
- \* To connect a braking resistor, follow in APPENDIX A.  
Improper connection may cause the unit damaged or a fire.
- \* Tighten terminal screws.  
Failure to observe this caution can result a fire.
- \* Never connect the AC main circuit power supply to output terminals U, V and W.  
The inverter will be damaged and invalidate the guarantee.

---

## OPERATION

---



## WARNING

- \* Only turn ON the input power supply after replacing the front cover.  
Do not remove the cover while current is flowing.  
Failure to observe this warning can result in an electrical shock.



## CAUTION

- \* Since it is easy to change. operation speed from low to high speed, verify the safe working range of the motor and machine before operation.  
Failure to observe this caution can result in personal injury and machine damage.
- \* Do not change signals during operation.  
The machine or the inverter may be damaged.
- \* All the constants of the inverter have been preset at the factory.  
Do not change the settings unnecessary.

---

## MAINTENANCE AND INSPECTION

---

### WARNING

- \* Never touch high-voltage terminals in the driver.  
Failure to observe this warning can result in an electrical shock.
- \* Replace all protective covers before powering up the inverter.  
To remove the cover, make sure to shut OFF the molded-case circuit breaker.  
Failure to observe this warning can result in an electrical shock.
- \* Perform maintenance or inspection only after verifying that the CHARGE LED goes OFF, after the main circuit power supply is turned OFF.  
The capacitors are still charged and can be dangerous.
- \* Only authorized personnel should be permitted to perform maintenance, inspections or parts replacement.  
Failure to observe this warning can result in an electrical shock.

## **CAUTION**

- \* The control PC board employs CMOS ICs. Do not touch the CMOS elements by hand.  
They are easily damaged by static electricity.
- \* Do not connect or disconnect wires or connectors while power is applied to the circuit.  
Failure to observe this caution can result in personal injury.

---

## **OTHERS**

---



### **WARNING**

- \* Never modify the product.  
Failure to observe this warning can result in an electrical shock or personal injury and will invalidate the guarantee.

# CONTENTS

1. RECEIVING .....	1
2. SPECIFICATIONS .....	2
3. DIMENSION DRAWINGS .....	4
4. INSTALLATION .....	7
5. DESCRIPTION OF TERMINALS .....	9
6. DIGITAL OPERATION PANEL .....	15
7. FUNCTIONS DESCRIPTION .....	16
8. DISPLAY ERROR CODES .....	44
9. HARDWARE PROTECTIVE FUNCTIONS .....	47
10. PRECAUTIONS .....	48
11. TROUBLESHOOTING .....	49
12. APPLICATION .....	50
13. INVERTER SELECTION .....	54
14. APPENDIX .....	56
A. Optional braking resistor .....	56
B. Terminal wiring diagram .....	57
C. Remote operator .....	59
D. Version .....	60

# 1. RECEIVING

This AS series AC drive has gone through rigorous quality control tests at the factory before shipment. After receiving the AC drive, please check for the following :

- (1) No damage is found on each product after shipping.
- (2) The product is as ordered (check the nameplate, voltage and frequency).
- (3) A set of inverter unit and instruction manual is contained in the package.

For any irregularity, contact the sales shop where you purchased immediately.

- (4) Description of name plate

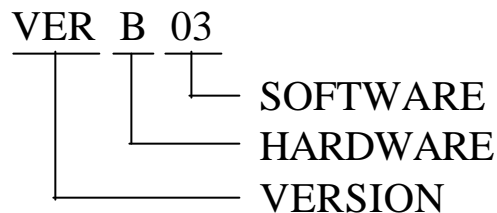
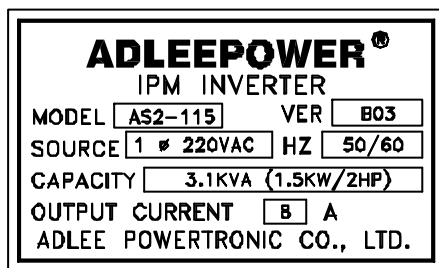

MODEL : AS 2 - 115 R

AS series

Voltage class :

- 1 : 110V
- 2 : 220V
- 4 : 380/440V

- R : REMOTE CONTROL SERIES
- H : HIGH SPEED SERIES
- T : TIMING AND SPEED CONTROL SERIES
- RP : REMOTE CONTROL AND PID CONTROL SERIES
- RT : REMOTE CONTROL AND SPEEDS WITH TIMING CONTROL SERIES
- Max Applicable motor(4 pole)

Single Phase :





- 104 : 0.4KW    107 : 0.75KW    115 : 1.5KW
- 122 : 2.2KW    137 : 3.7KW

3 Phase :





- 304 : 0.4KW    307 : 0.75KW    315 : 1.5KW
- 322 : 2.2KW    337 : 3.7KW

## 2. SPECIFICATIONS

### (1) Single phase input port

Model	AS1		AS2				
Voltage	1 110VAC $\pm$ 10%		1 220VAC $\pm$ 10%				
Model No	AS1-104	AS1-107	AS2-104	AS2-107	AS2-115	AS2-122	AS2-137
Input Frequency	50HZ ~ 60HZ $\pm$ 10%						
Output Voltage	3 220VAC						
Output Frequency	0.5 ~ 400HZ / 0.5 ~ 2000HZ (High frequency)						
Output Rated current (A)	3 A	5 A	3 A	5 A	8 A	11 A	17 A
Capacity (KVA)	1.1 KVA	1.9 KVA	1.1 KVA	1.9 KVA	3.1 KVA	4.2 KVA	6.5 KVA
Largest motor KW ( 4 poles )	0.4KW	0.75KW	0.4KW	0.75KW	1.5KW	2.2KW	3.7KW
Control	Sine wave pulse width modulation						
Braking	Regenerative discharge braking						
Over current Capacity	150% of rated current ( 1 minute)						
Acceleration time	0.1 ~ 6000 SEC						
Deceleration time	0.1 ~ 6000 SEC						
Frequency setting	Digital	Use keyboard    for setting and confirm by 					
	Analog	By frequency knob					
Display type	LED Digits						
Cooling Method	Self-cooled	Air-cooled	Self-cooled	Self-cooled	Air-cooled	Air-cooled	Air-cooled
Dimension drawing	Fig 1	Fig 2	Fig 1	Fig 1	Fig 2	Fig 2	Fig 3
Weight ( NW . KG )	1.2KG	1.3KG	1.2KG	1.3KG	1.3KG	1.4KG	4.0KG

## (2) 3 Phase input port

Model	AS2					AS4			
Voltage	3 220VAC $\pm$ 10%					3 380/440VAC $\pm$ 10%			
Model No	AS2-304	AS2-307	AS2-315	AS2-322	AS2-337	AS4-307	AS4-315	AS4-322	AS4-337
Input Frequency	50HZ ~ 60HZ $\pm$ 10%								
Output Voltage	3 220VAC					3 380/440VAC			
Output Frequency	0.5 ~ 400HZ / 0.5 ~ 2000HZ (High frequency)								
Output Rated current (A)	3 A	5 A	8 A	11 A	17 A	2.5 A	4 A	6 A	9 A
Capacity (KVA)	1.1 KVA	1.9 KVA	3.1 KVA	4.2 KVA	6.5 KVA	1.9 KVA	3.1 KVA	4.2 KVA	6.9 KVA
Largest motor KW ( 4 poles )	0.4 KW	0.75 KW	1.5 KW	2.2 KW	3.7 KW	0.75 KW	1.5 KW	2.2 KW	3.7 KW
Control	Sine wave pulse width modulation								
Braking	Regenerative discharge braking								
Over current Capacity	150% of rated current ( 1 minute)								
Acceleration time	0.1 ~ 6000 SEC								
Deceleration time	0.1 ~ 6000 SEC								
Frequency setting	Digital	Use keyboard    for setting and confirm by 							
	Analog	By frequency knob							
Display type	LED Digits								
Cooling Method	Self-cooled	Self-cooled	Air-cooled	Air-cooled	Air-cooled	Air-cooled	Air-cooled	Air-cooled	Air-cooled
Dimension drawing	Fig 1	Fig 1	Fig 2	Fig 2	Fig 3	Fig 2	Fig 2	Fig 3	Fig 3
Weight ( NW . KG )	1.2 KG	1.3 KG	1.3 KG	1.4 KG	4.0 KG	1.3 KG	1.3 KG	4.0 KG	4.2 KG

### 3. DIMENSION DRAWINGS

Unit : mm

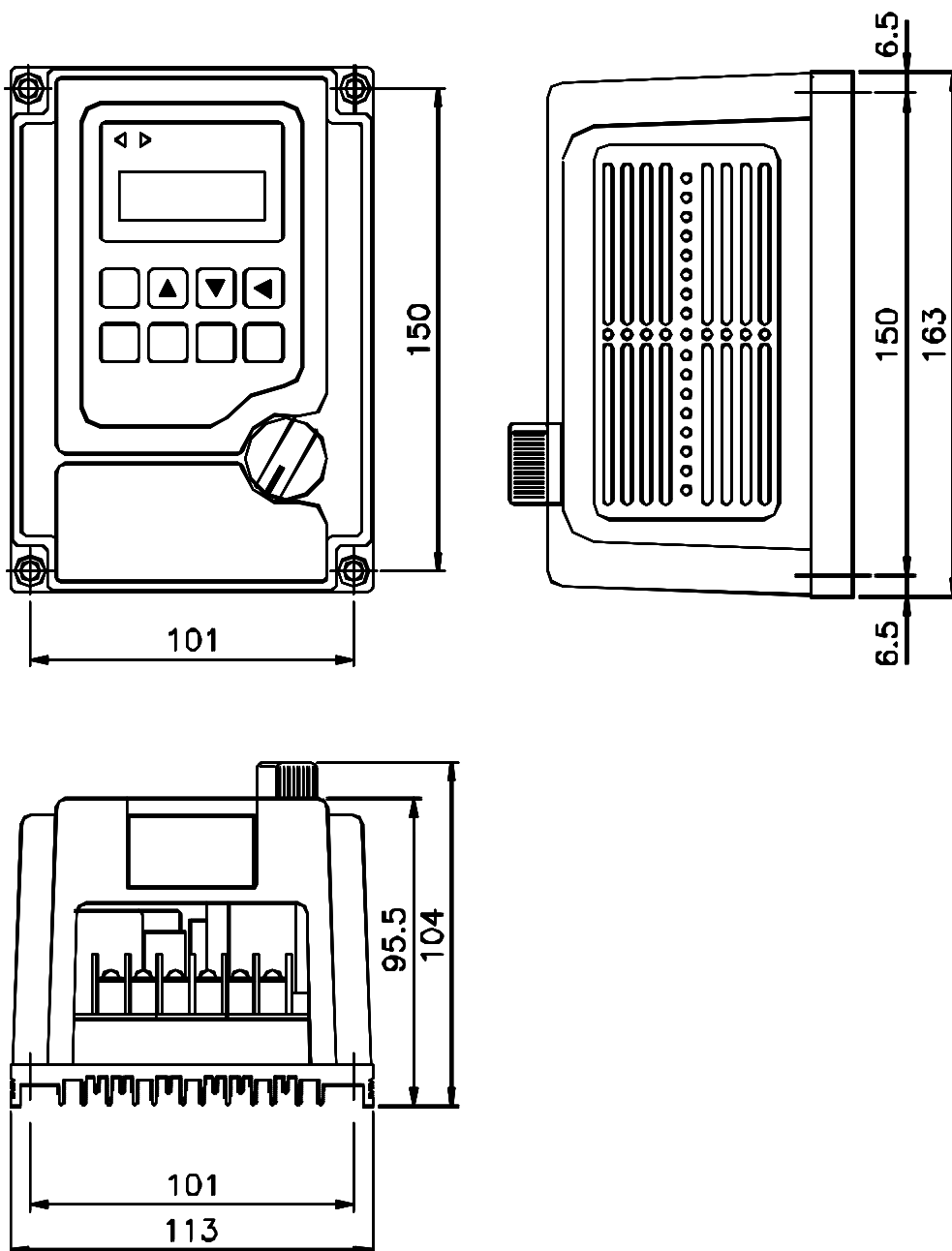
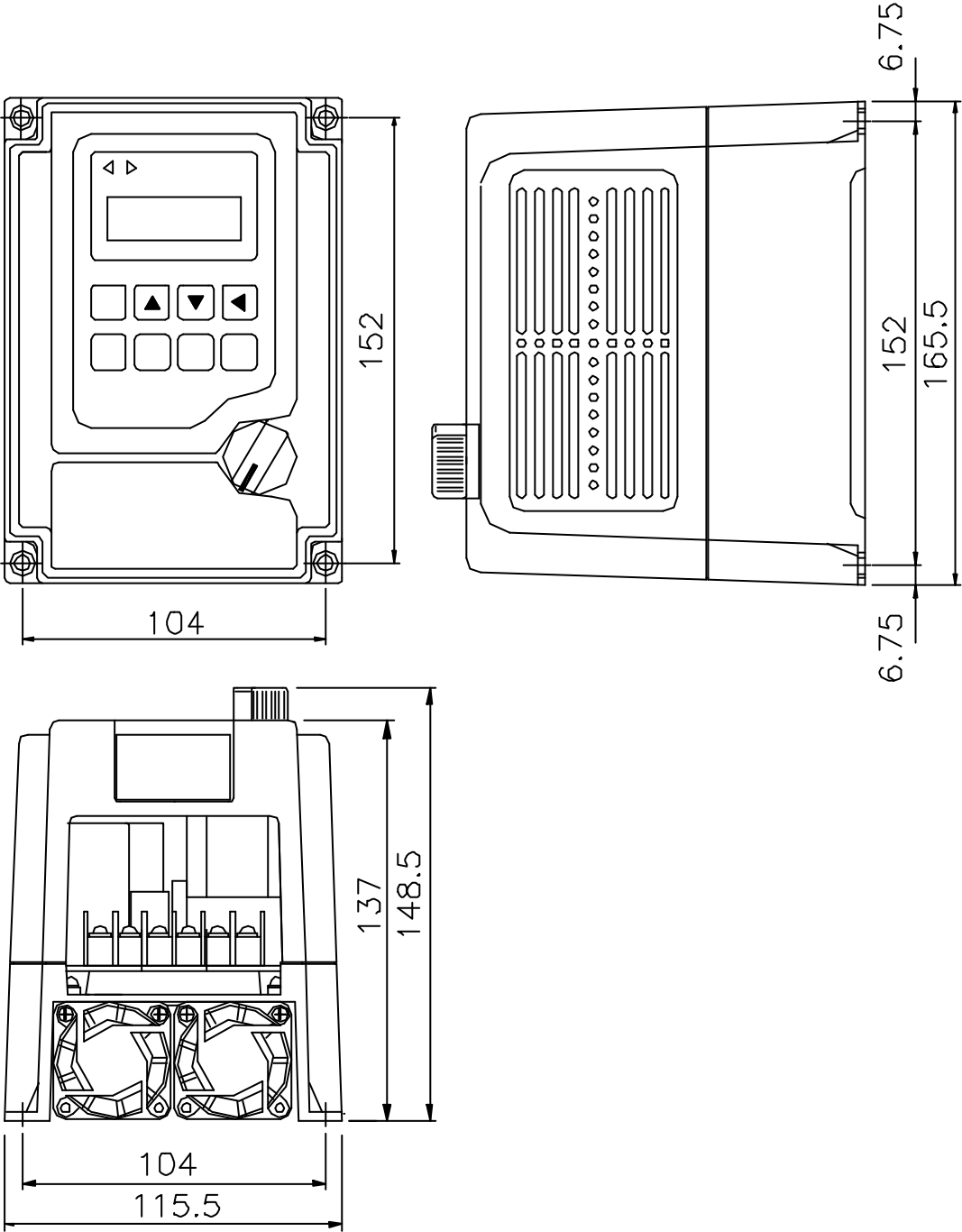

Fig 1

Unit : mm



**Fig 2**

Unit : mm

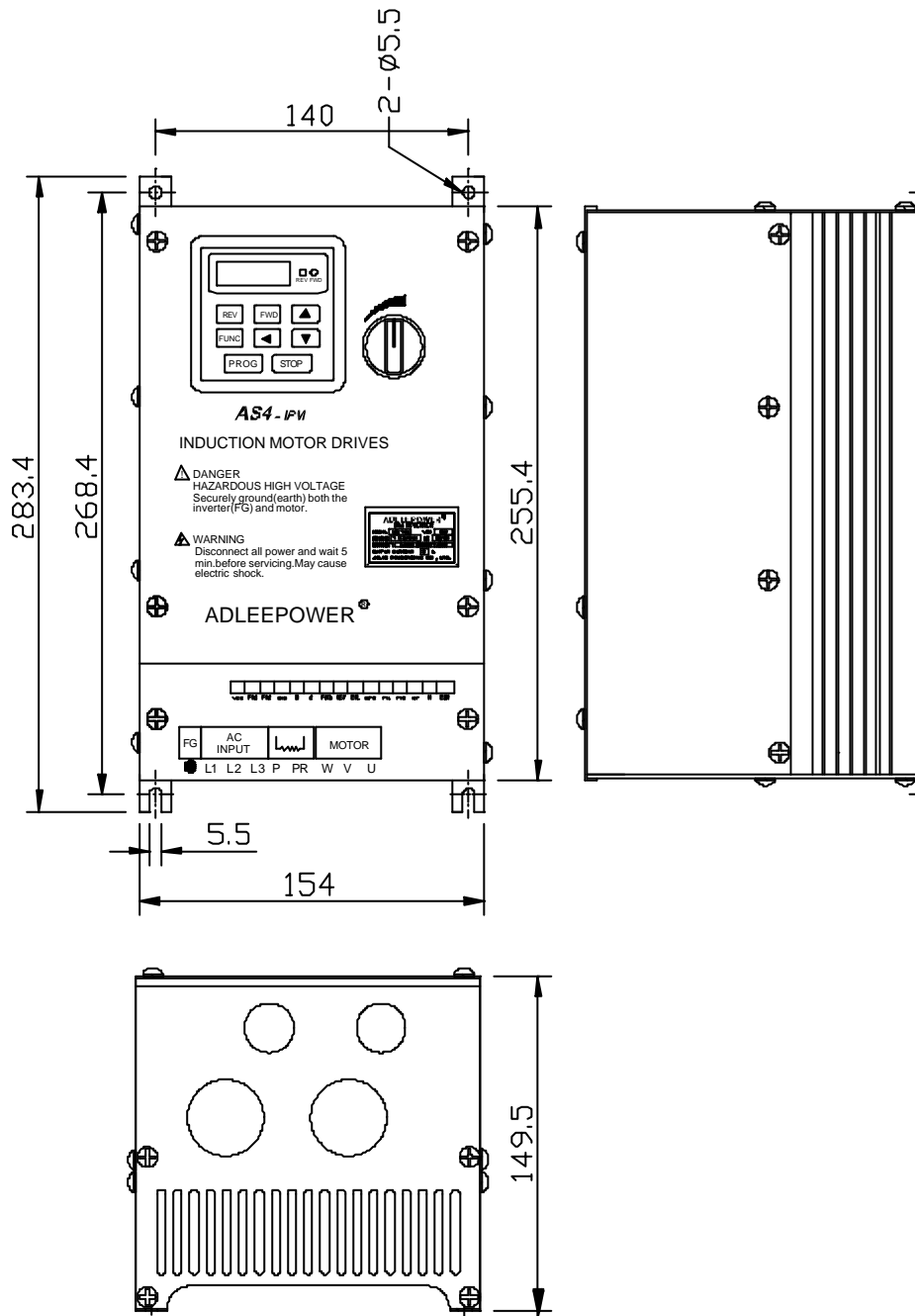

Fig 3

## 4. INSTALLATION

Inadequate environment around installation site and installation surface can result in damage to the inverter.

Before operating the AS series inverter, please check the following points :

- (1) Avoid high temperature, high humidity, easy-to-dew ambient environment. Don't expose to dust or dirt, corrosive gas, and coolant mist, and direct sunlight. Place the unit in a well-ventilated room.
- (2) Avoid a place subjected to substantial vibration.
- (3) When installing the unit within the cabinet. Please pay attention to ventilation and limit the ambient temperature in between  $-10 \sim 45$  . ( $14 \sim 113$  ).
- (4) Use a nonflammable material, such a steel sheet on the wall for installation. (The rear side will generate heat)
- (5) Install the unit always vertically with a marginal spacing around.

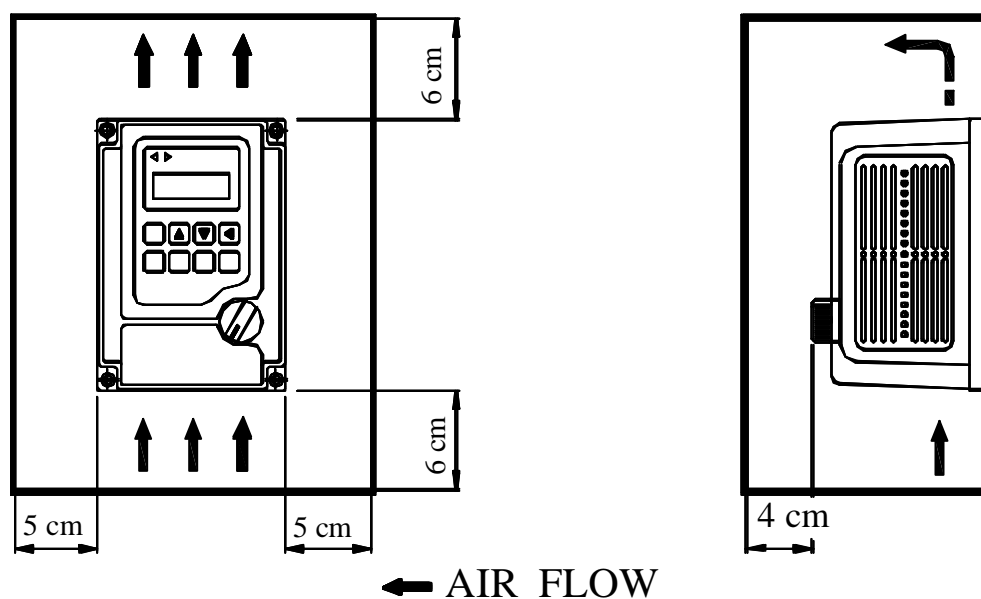

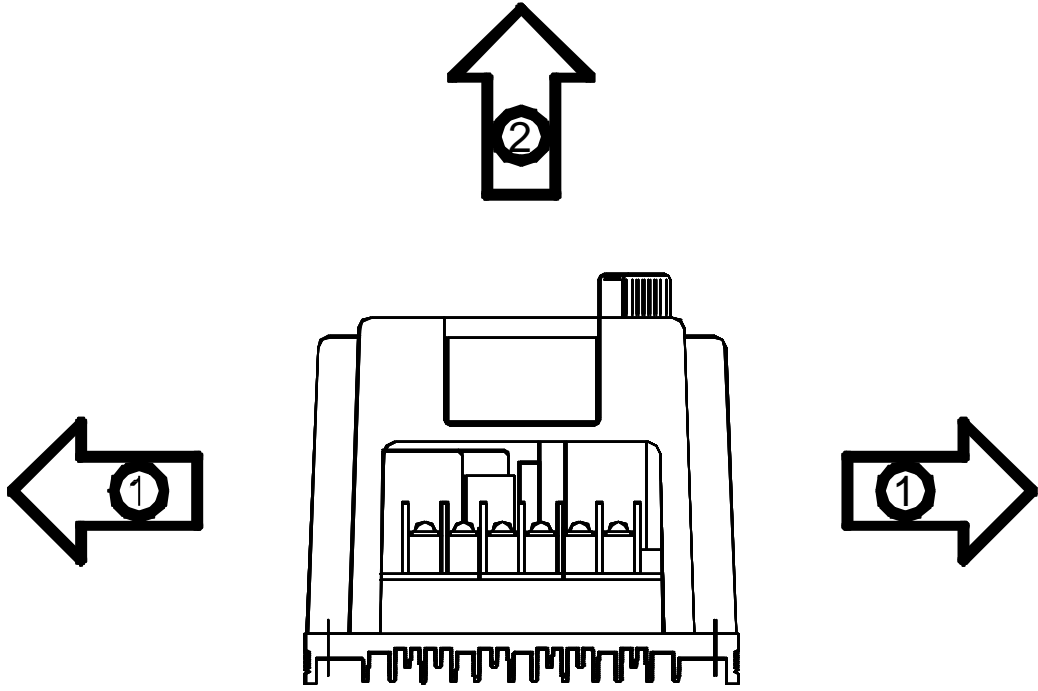
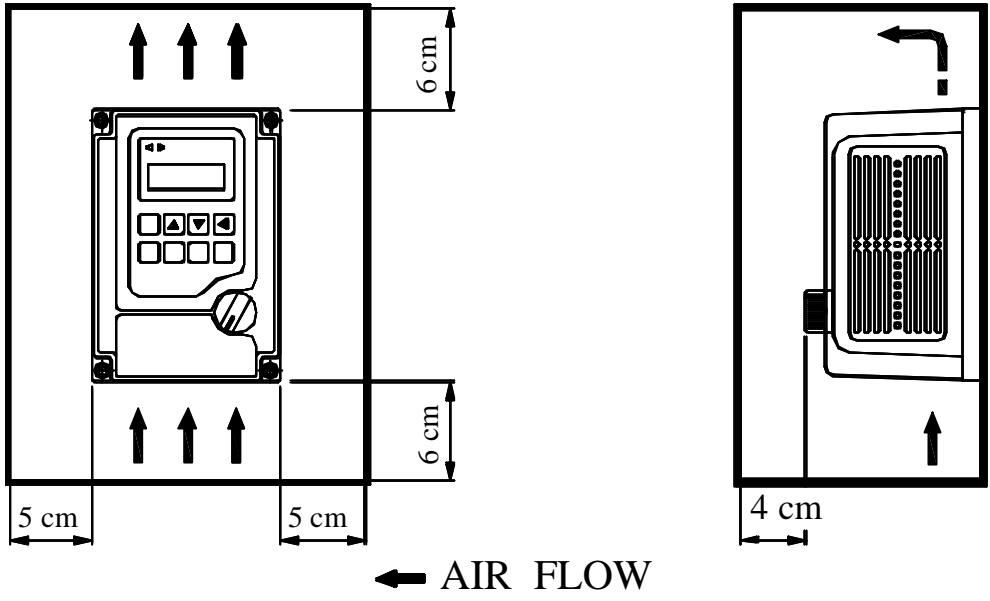

## 5. DESCRIPTION OF TERMINALS

### (1) Main circuit connection diagram

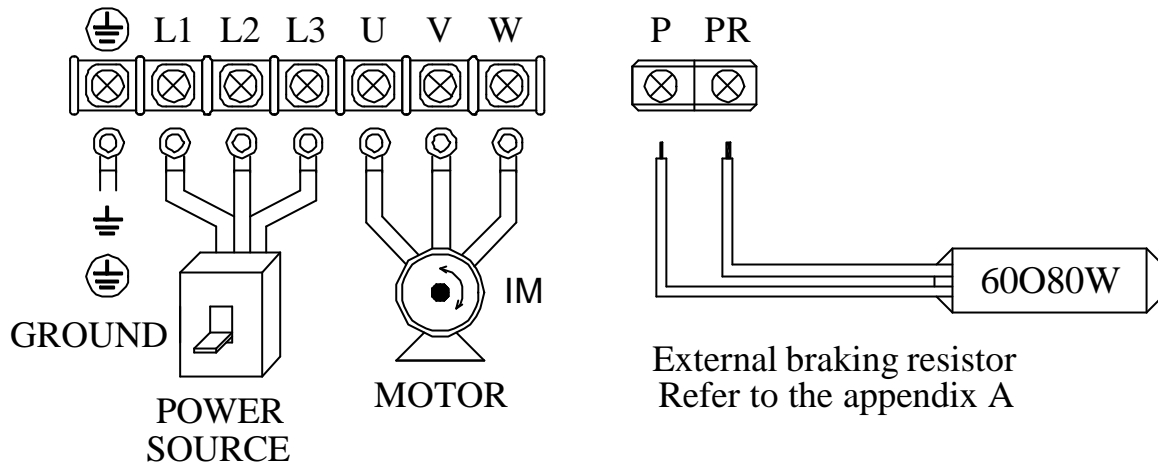

Main circuit terminal			
No.	Symbol	Description	Terminal name
1		Ground	Ground(Earth) Terminal
2	L1	Connect power supply	(L1,L2) Single Phase (L1,L2,L3) 3 Phase
3	L2		
4	L3		
5	U	Inverter output	Terminals connected to motor
6	V		
7	W		
8	P	Dynamic brake	Terminals connected to braking Resistor
9	PR		

(2) Control circuit terminal

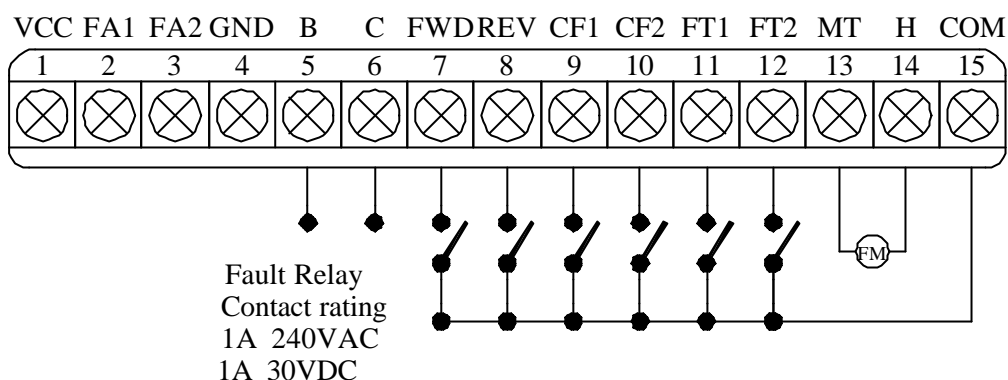



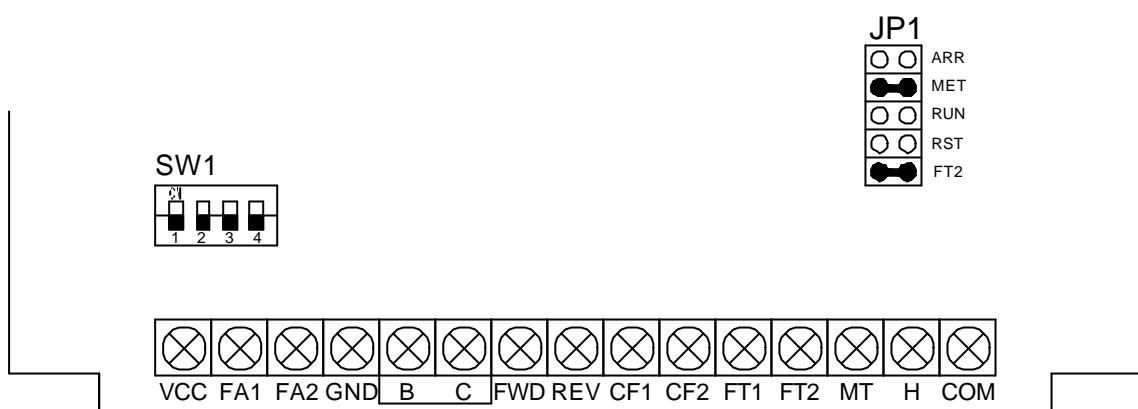

No	Symbol	Multi function analog terminal	
1	VCC	Analog source	Power source +5V of analog terminals
2	FA1	Free analog terminal 1	See CD44 & 3-1 SW1
3	FA2	Free analog terminal 2	See CD45 & 3-1 SW1
4	GND	Analog common terminal	Common terminal of free analog terminals

Control circuit terminal																		
No	Symbol	Terminal name	Description															
5	B	Alarm output B	Fault alarm contact (normal close)															
6	C	Alarm output C	Fault alarm contact (common)															
7	FWD	Forward operation	Forward operation / stop terminal															
8	REV	Reverse operation	Reverse operation / stop terminal															
9	CF1	Multistage speed terminal	<table border="1"> <thead> <tr> <th>CF1</th> <th>CF2</th> <th>SPEED</th> </tr> </thead> <tbody> <tr> <td>OFF</td> <td>OFF</td> <td>SPEED - 1</td> </tr> <tr> <td>ON</td> <td>OFF</td> <td>SPEED - 2</td> </tr> <tr> <td>OFF</td> <td>ON</td> <td>SPEED - 3</td> </tr> <tr> <td>ON</td> <td>ON</td> <td>SPEED - 4</td> </tr> </tbody> </table>	CF1	CF2	SPEED	OFF	OFF	SPEED - 1	ON	OFF	SPEED - 2	OFF	ON	SPEED - 3	ON	ON	SPEED - 4
CF1	CF2		SPEED															
OFF	OFF	SPEED - 1																
ON	OFF	SPEED - 2																
OFF	ON	SPEED - 3																
ON	ON	SPEED - 4																
10	CF2																	
11	FT1	Multi function terminal 1	See functions description (CD42)															
12	FT2	Multi function terminal 2	See functions description (CD43)															
13	MT	Multi function output terminal (SEE 3-2 JP1)																
14	H	Ref source +10V	Basic source +10V 20mA															
15	COM	Common terminal	Common terminal of control terminals															

### (3) Description of Hardware setting

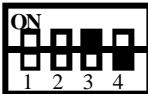
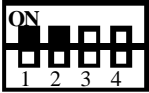
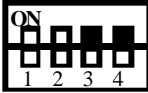
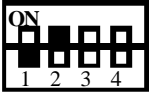

#### 3-1 DIP Switch setting (SW1)

Setting FA1		Setting FA2	
	FA1 : 0 - 10V		FA2 : 0 - 10V
	FA1 : 0 - 5V		FA2 : 0 - 5V
	FA1 : 4 - 20mA		FA2 : 4 - 20mA
	Error setting		Error setting

#### 3-2 Jumper Setup (JP1)

MT : Multi function output terminal selector signal

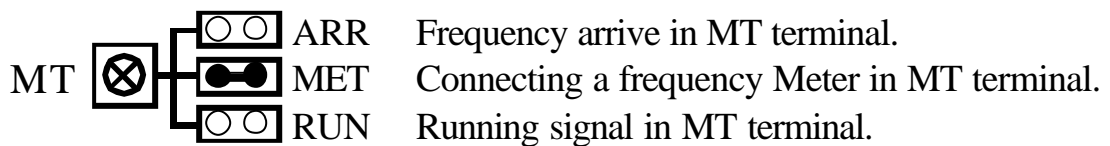

FT2 : Free Terminal 2 function selector



## (4) WIRING

### 4-1 Wiring of main circuit

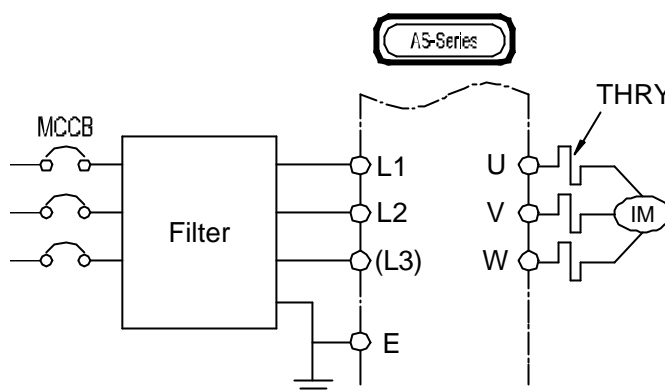

### 4-2 Wiring equipments

Select the wiring equipment and wiring size, refer to the table below.

1. On the input power side, a molded case circuit breaker (MCCB) to protect inverter primary wiring should be installed.
2. A leakage current breaker threshold of 200mA and above, or of inverter use is recommended.
3. Use of input side magnetic contactor. An input MC can be used to prevent an automatic restart after recovery from an external power loss during remote control operation. However, do not use the MC reduced reliability.
4. In general, magnetic contactors on the output of the inverter, Should not be used for motor control. Starting a motor with the inverter running will cause large surge currents and the inverter overcurrent protector to trigger.

Model	AS1		AS2					AS4			
Model No	04	07	04	07	15	22	37	07	15	22	37
Capacity (KVA)	1.1	1.9	1.1	1.9	3.1	4.2	6.5	1.9	3.1	4.2	6.5
Current (A)	3	5	3	5	8	11	17	2.5	4	6	9
Circuit Breaker (MCCB) (A)	15	15	10	10	15	20	20	10	10	10	15
Electro-Magnetic Contactor (A)	12	12	12	12	12	12	18	12	12	12	12
Thermal relay RC value (A)	4.8	7.6	2.4	3.8	6.8	9	15	1.9	3.4	3.8	6.8

### 4-3 Surge absorber

In order to prevent malfunction, provide the surge absorber on the coils of the electromagnetic contactors, relays and other devices which are to be used adjacent of the inverter.

### 4-4 Cable size and length

If the inverter is connected to a distant motor (especially when low frequency is output), motor torque decreases because of voltage drop in the cable. Use sufficiently heavy wire.

Changing the carrier frequency reduce RF1 noise and leakage current. (Refere to the table below)

Distance INVERTER MOTOR	under 25M	under 50M	under 100M	above 100M
AS2 SERIES	under 16KHZ	under 10KHZ	under 5KHZ	under 2.5KHZ

### 4-5 EMI filter specifications

AS SERIES	FREQUENCY (MHZ)					
	0.15	0.5	1	5	10	30
Typical insertion loss (dB)	11	50	62	65	65	60

## 4-6 Wiring and cautionary points

### A. Main circuit

1. Connect the cables of the power supply side to the U, V and W output terminals for the motor.
2. Don't connect any electromagnetic contactor between the inverter and motor. If it is inevitable, turn on the contactor when both the inverter and motor are both at stand still.
3. Don't put the advance phase capacitor between the inverter and motor.
4. Put MCCB in the input power supply.

### B. Control signal circuit

1. Separate the power cables of main circuit etc. from the control cables of the sequence and analog signals by passing the cables through the different ducts.
2. Use twisted pair shielded wire for control signal and connect the shield to earth terminal at one end, COMMON terminal of control board. Leave the other end of shielding open.
3. Avoid common Ground leads between high and low level voltage equipment.





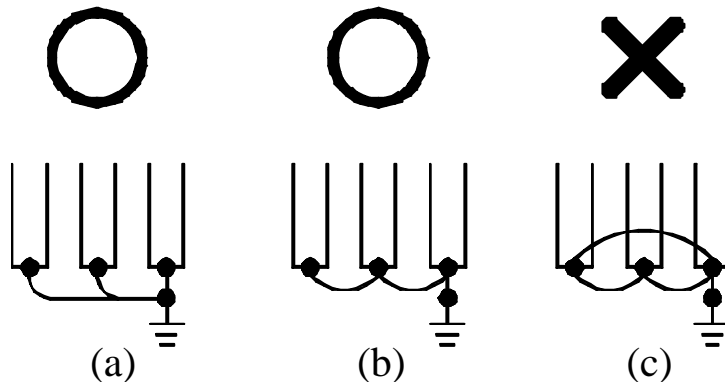

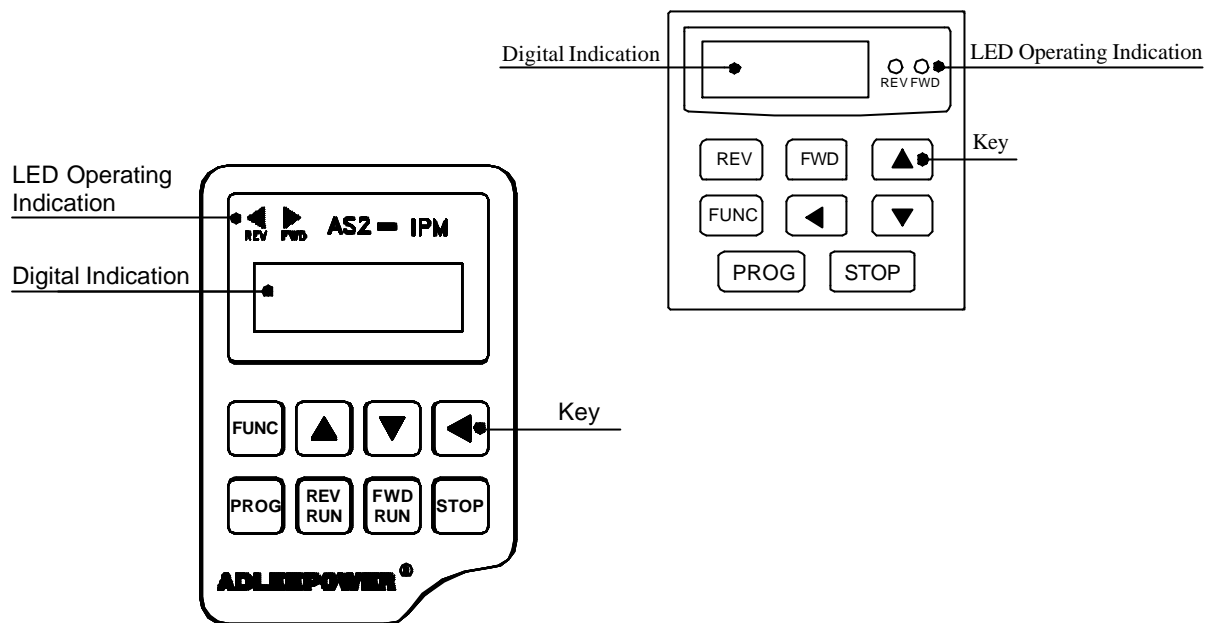

### C. Grounding

1. Be sure ground both the inverter and motor.
2. Keep grounded leads as short as possible.
3. Shield cables used to protect low-level signal leads should be grounded at one end point.
4. Provide class 3 grounding (100  $\Omega$  or less) for a terminal.
5. When grounding several inverters, make connections as shown below, no loop is produced as shown in FIG "a", FIG "b".



## 6. DIGITAL OPERATION PANEL



Operation key		Key function	Description
	FWD RUN	Forward run	Commands forward run
	REV RUN	Reverse run	Commands reverse run
	SHIFT	Cursor movement	Select the digit
	DOWN	Down	Decrease the parameter value
	UP	Up	Increase the parameter value
	PROG	Memory storage	Saves the setting vaule
	FUNC	Function	Press once to select function CDxx and press again to change its content
	STOP	Stop	Stop operation / Escape to standby mode

## 7. FUNCTIONS DESCRIPTION

DISPLAY ORDER	FUNCTION NAME	STANDARD SETTING VALUE
CD00	First speed setting	U : 60HZ
		E : 50(B03) / 0(B04)
CD01	Parameter lock	0
CD02	Acceleration time 1	10 Sec
CD03	Deceleration time 1	10 Sec
CD04	Jogging frequency	5HZ
CD05	Start frequency	0.5HZ
CD06	Jog mode	0
CD07	Frequency meter correspond	U : 120 HZ
		E : 100 HZ
CD08	CW or CCW or CW / CCW	0
CD09	Reserved	0
CD10	Keyboard / Analog signal from terminal	0
CD11	Dynamic brake / Free running	0
CD12	Terminal / Key board command	0
CD13	Reserved	
CD14	Maximum frequency limit	U : 120 HZ
		E : 50 HZ
CD15	Minimum frequency limit	0
CD16	Frequency display Scale	U : 1
		E : 30
CD17	Maximum voltage frequency	U : 60 HZ
		E : 50 HZ

Different initial set value for E : European version and U : US version.  
To change version see description of CD52.

<b>CHANGEABLE OF SETTING VALUE</b>	<b>UNIT</b>	<b>USER SETTING</b>	<b>REMARK</b>
<b>0 ~ 400 HZ</b>	<b>0.01 HZ</b>		
<b>0 or 1</b>	<b>----</b>		<b>0 = lock 1 = Unlock</b>
<b>0.1 ~ 6000 Sec</b>	<b>0.1 Sec</b>		
<b>0.1 ~ 6000 Sec</b>	<b>0.1 Sec</b>		
<b>0 ~ 400 HZ</b>	<b>0.01 HZ</b>		
<b>0.5 ~ 30 HZ</b>	<b>0.01 HZ</b>		
<b>0 or 1</b>	<b>----</b>		<b>0 = Normal 1 = Jog</b>
<b>30 ~ 400 HZ</b>	<b>0.01 HZ</b>		
<b>0 ~ 2</b>	<b>----</b>		<b>0 = CW/CCW 1 = CW 2 = CCW</b>
<b>0 or 1</b>	<b>----</b>		<b>0 = Keyboard input 1 = Frequency knob</b>
<b>0 or 1</b>	<b>----</b>		<b>0 = Dynamic brake 1 = Free running</b>
<b>0 or 1</b>	<b>----</b>		<b>0 = Keyboard 1 = Terminal</b>
<b>0.5 ~ 400 HZ</b>	<b>0.01 HZ</b>		
<b>0 ~ 400 HZ</b>	<b>0.01 HZ</b>		
<b>0.01 ~ 500</b>	<b>0.01</b>		<b>Display = Frequency × Scale</b>
<b>25 ~ 400 HZ</b>	<b>0.01 HZ</b>		

<b>DISPLAY ORDER</b>	<b>FUNCTION NAME</b>	<b>STANDARD SETTING VALUE</b>
<b>CD18</b>	<b>V/F pattern setting</b>	<b>0</b>
<b>CD19</b>	<b>DC braking time</b>	<b>1 Sec</b>
<b>CD20</b>	<b>DC braking power</b>	<b>10</b>
<b>CD21</b>	<b>Torque boost</b>	<b>0 %</b>
<b>CD22</b>	<b>Second speed setting</b>	<b>20 (B03) / 0 (B04)</b>
<b>CD23</b>	<b>Third speed setting</b>	<b>30 (B03) / 0 (B04)</b>
<b>CD24</b>	<b>Fourth speed setting</b>	<b>40 (B03) / 0 (B04)</b>
<b>CD25</b>	<b>Acceleration time 2</b>	<b>10 Sec</b>
<b>CD26</b>	<b>Deceleration time 2</b>	<b>10 Sec</b>
<b>CD27</b>	<b>Carrier frequency</b>	<b>16 KHZ</b>
<b>CD28</b>	<b>Output voltage gain</b>	<b>100 %</b>
<b>CD29</b>	<b>Frequency jump 1</b>	<b>0 HZ</b>
<b>CD30</b>	<b>Frequency jump 2</b>	<b>0 HZ</b>
<b>CD31</b>	<b>Frequency jump 3</b>	<b>0 HZ</b>
<b>CD32</b>	<b>Jump range</b>	<b>0.5 HZ</b>
<b>CD33</b>	<b>Frequency reference bias</b>	<b>0</b>
<b>CD34</b>	<b>Frequency reference bias direction</b>	<b>0</b>
<b>CD35</b>	<b>Frequency gain</b>	<b>100.0 %</b>
<b>CD36</b>	<b>The latest error record</b>	<b>NONE</b>
<b>CD37</b>	<b>Errors record 1</b>	<b>NONE</b>

<b>CHANGEABLE OF SETTING VALUE</b>	<b>UNIT</b>	<b>USER SETTING</b>	<b>REMARK</b>
<b>0 ~ 2</b>	<b>----</b>		<b>0 : Constant torque 1 : (Frequency) 2.0 2 : (Frequency) 3.0</b>
<b>0 ~ 25 Sec</b>	<b>0.1 Sec</b>		
<b>0 ~ 250</b>	<b>1.00</b>		
<b>0 ~ 25%</b>	<b>0.1 %</b>		
<b>0 ~ 400 HZ</b>	<b>0.01 HZ</b>		
<b>0 ~ 400 HZ</b>	<b>0.01 HZ</b>		
<b>0 ~ 400 HZ</b>	<b>0.01 HZ</b>		
<b>0.1 ~ 6000 Sec</b>	<b>0.1 Sec</b>		
<b>0.1 ~ 6000 Sec</b>	<b>0.1 Sec</b>		
<b>1KHZ ~ 16KHZ</b>	<b>0.1 KHZ</b>		
<b>50 ~ 100 %</b>	<b>0.1 %</b>		
<b>0 ~ 400 HZ</b>	<b>0.01 HZ</b>		
<b>0 ~ 400 HZ</b>	<b>0.01 HZ</b>		
<b>0 ~ 400 HZ</b>	<b>0.01 HZ</b>		
<b>0.5 ~ 3 HZ</b>	<b>0.01 HZ</b>		
<b>0 ~ 400 HZ</b>	<b>0.01 HZ</b>		
<b>0 or 1</b>	<b>----</b>		<b>0 = Positive 1 = Negative</b>
<b>40 ~ 200 %</b>	<b>0.1 %</b>		



<b>DISPLAY ORDER</b>	<b>FUNCTION NAME</b>	<b>STANDARD SETTING VALUE</b>
CD38	Errors record 2	NONE
CD39	Errors record 3	NONE
CD40	Clear errors record	0
CD41	HZ / RPM Display	0
CD42	FT1 Multi-Function Terminal 1	0
CD43	FT2 Multi-Function Terminal 2	0
CD44	FA1 Free Analog Terminal 1	0
CD45	FA2 Free Analog Terminal 2	0
CD46	Reserved	
CD47	5th speed setting	25 (B03) / 0 (B04)
CD48	6th speed setting	35 (B03) / 0 (B04)
CD49	7th speed setting	45 (B03) / 0 (B04)
CD50	8th speed setting	55 (B03) / 0 (B04)
CD51	Dynamic Braking Energy Limit	100
CD52	Version selector	
CD53	S curve	0
CD54	4 ~ 20mA speed command	0
CD55	Frequency arrive signal range	10 %
CD56	2nd Maximum voltage frequency	60 HZ
CD57	No, of auto restart attempt	0

This function provides different standard setting values for European and USA Version.

CHANGEABLE OF SETTING VALUE	UNIT	USER SETTING	REMARK
	----		
0 or 1	----		1 = Clear
0 or 1	----		0 = HZ Display 1 = RPM Display
0 or 1	----		
0 ~ 15	----		RESET SEE 3-2 JP1
0 ~ 15	----		
0 ~ 15	----		
0 ~ 400 HZ	0.01 HZ		
0 ~ 400 HZ	0.01 HZ		
0 ~ 400 HZ	0.01 HZ		
0 ~ 400 HZ	0.01 HZ		
0 ~ 300	1		0 = Auto turning
Eur European Version			
USA US Version			
0 ~ 10			0 = Normal 1~10 = S Surve
0 ~ 3			
0 ~ 100 %	1 %		
25 ~ 400 HZ	0.01 HZ		
0 ~ 10	----		

## 7-1. Function setting

Before starting test run, check carefully the following points :

- (1) Be sure to connect the power supply to L1, L2, L3 (input terminals) and the motor to U.V.W. (output terminals). (Wrong connections will damage the inverter.)
- (2) Check that the input power supply coincide with input voltage and input phase of the inverter.
- (3) Check the signal lines for correct wiring.
- (4) Be sure to ground an earth terminal for personnel safety.
- (5) Check that other terminals other than earth terminal are not grounded.
- (6) Check that the inverter is mounted on the wall. Also check that non-flammable material.
- (7) For operation start and stop, use    and FWD / REV terminals. Never use input power supply to switch ON/OFF.

### Operating

Action : (a) Press   for forward / reverse operation.

function : (a) Press    for function setting and confirm by  .



speed : (a) Using frequency knob for motor speed setting.

(b) Using keyboard   and  for motor speed setting. set CD10 = 0 at first, see Function description

Standby : (a) Press  back to standby mode after trip or function setting mode.

<b>First speed setting</b>
<b>CD00</b>

<b>Setting Range</b>	<b>0 ~ 400 HZ</b>
<b>USA Version</b>	<b>60 HZ</b>
<b>European Version</b>	<b>50 (B03) / 0 (B04)</b>

Press   key for increase or decrease the speed with 1HZ increment step for quick setting.

Press  key to select the digit.

Press  to save the setting value.

<b>Parameter lock</b>
<b>CD01</b>

<b>Setting Range</b>	<b>0 or 1</b>
<b>Factory Setting</b>	<b>0</b>

0 : Lock 1 : Unlock

Function to prevent inadequate setting.

To change the contents CD02 ~ CD56 , set CD01=1 and press  first.

To lock the data set CD01=0 and press  .

<b>Acceleration time 1</b>
<b>CD02</b>

<b>Setting Range</b>	<b>0.1 ~ 6000 Sec</b>
<b>Factory Setting</b>	<b>10 Sec</b>

CD02 value corresponds to the time of acceleration from the minimum frequency to 60HZ.(For 120Hz. setting, the arrival time to 120Hz is double.)

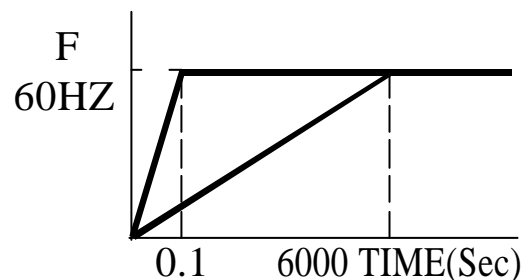

<b>Deceleration time 1</b>
<b>CD03</b>

<b>Setting Range</b>	<b>0.1 ~ 6000 Sec</b>
<b>Factory Setting</b>	<b>10 Sec</b>

CD03 value corresponds to the time of deceleration from 60HZ to the minimum frequency.

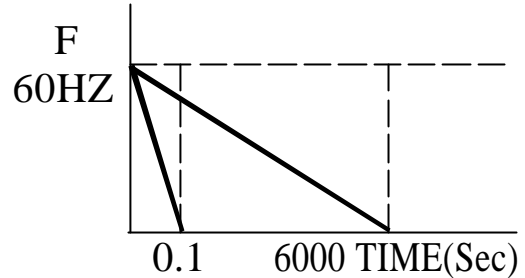

<b>Jogging frequency</b>
<b>CD04</b>

<b>Setting Range</b>	<b>0 ~ 400 HZ</b>
<b>Factory Setting</b>	<b>5 HZ</b>

Use terminal control refer to CD12 and CD42 setting, keyboard control refer to CD06.

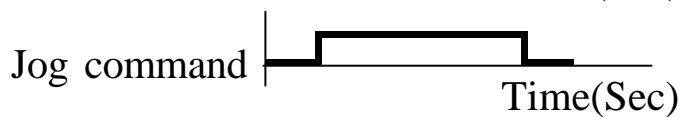
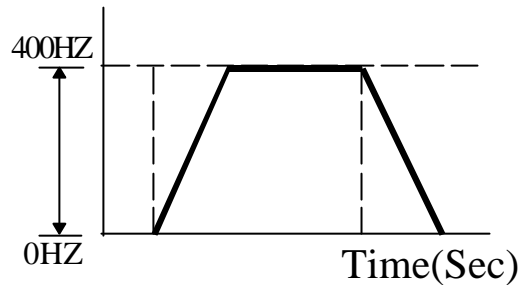

<b>Start frequency</b>
<b>CD05</b>

<b>Setting Range</b>	<b>0.5 ~ 30 HZ</b>
<b>Factory Setting</b>	<b>0.5 HZ</b>

When setting this value, pay attention to the starting current.

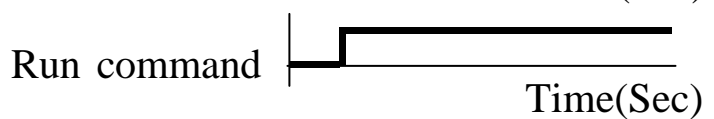
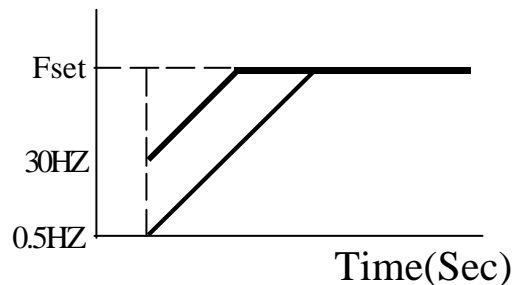

<b>Jog mode</b>
<b>CD06</b>

<b>Setting Range</b>	<b>0 or 1</b>
<b>Factory Setting</b>	<b>0</b>

0 : Normal      1 : Jog Mode

1. Set jogging operation from key panel **FWD RUN** & **REV RUN** .
2. **REV RUN** **FWD RUN** LED blinking in JOG mode.

<b>Frequency meter correspond</b>
<b>CD07</b>

<b>Setting Range</b>	<b>30.00 ~ 400.00 HZ</b>
<b>USA Version</b>	<b>120.00 HZ</b>
<b>European Version</b>	<b>100.00 HZ</b>

The specification of the output meter is 10V(i.e. 1mA) full scale rating and 30~400HZ frequency range.

Set by CD07 the value will be correspond to maximum correspond of output meter.

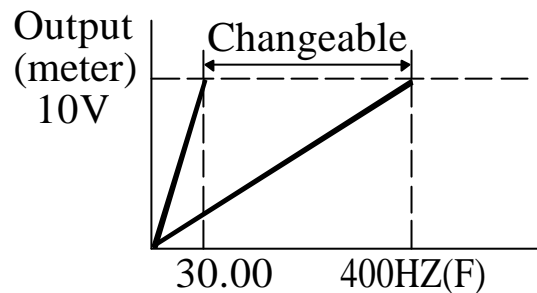

<b>CW or CCW or CW/CCW</b>
<b>CD08</b>



<b>Setting Range</b>	<b>0 ~ 2</b>
<b>Factory Setting</b>	<b>0</b>

- 0 : CW/CCW operation  
 1 : CW only  
 2 : CCW only



If inadequate operation, the “OPE2“ warning message would be indicated.

<b>Analog / Digital frequency</b>
<b>CD10</b>

<b>Setting Range</b>	<b>0 or 1</b>
<b>Factory Setting</b>	<b>1</b>

0 : Operation frequency change by using  or  key and confirm by  .

1 : Operation frequency change by adjusting the angle of the knob.

Note : Using   key to change motor speed when CD01=1, the “OPE3“ warning message would be indicated.

<b>Dynamic brake / Free running</b>
<b>CD11</b>

<b>Setting Range</b>	<b>0 or 1</b>
<b>Factory Setting</b>	<b>0</b>

0 : Activates dynamic brake function when deceleration. Decelerating time depends on CD3 setting.

1 : Output cut off when accept a stop command.

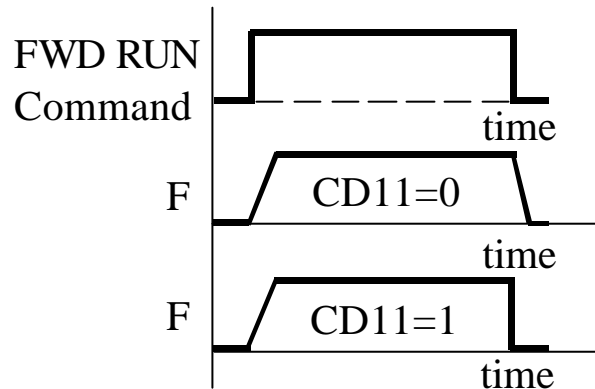

<b>Terminal / Key board command</b>
<b>CD12</b>

<b>Setting Range</b>	<b>0 or 1</b>
<b>USA Version</b>	<b>0</b>
<b>European Version</b>	<b>1</b>

0 : RUN/STOP Command from operation panel.

1 : RUN/STOP Command from control terminal.

Note : If inadequate operation, the “OPE4“ warning message would be indicated.

<b>Maximum frequency limit</b>
<b>CD14</b>

<b>Setting Range</b>	<b>0.5 ~ 400 HZ</b>
<b>USA Version</b>	<b>120 HZ</b>
<b>European Version</b>	<b>50 HZ</b>

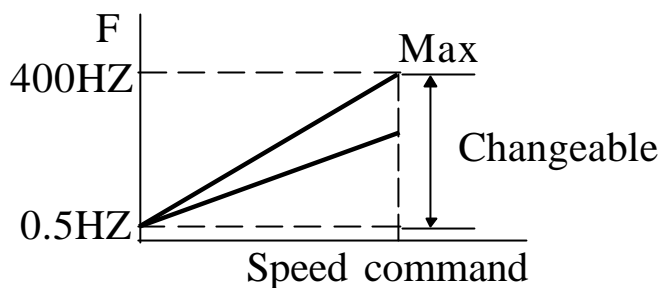

<b>Minimum frequency limit</b>
<b>CD15</b>

<b>Setting Range</b>	<b>0 ~ 400 HZ</b>
<b>Factory Setting</b>	<b>0</b>

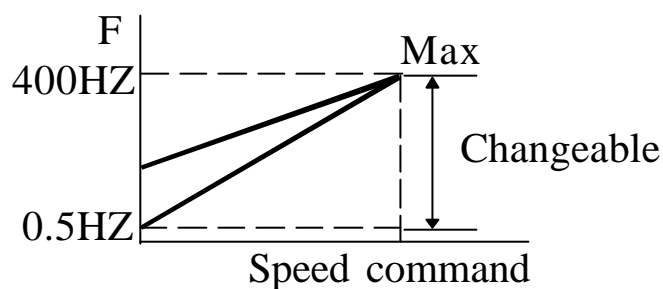

<b>Frequency display scale</b>
<b>CD16</b>

<b>Setting Range</b>	<b>0.5 ~ 400 HZ</b>
<b>USA Version</b>	<b>1 HZ</b>
<b>European Version</b>	<b>30 HZ</b>

Use the following equation to calculate the mechanical shaft speed in rpm.

$$\text{RPM} = \text{HZ} \times \text{Scale setting}$$

When  $\text{RPM} > 9999$  display 

-	-	E	-
---	---	---	---

 for over range warning.

Setting CD41=1 for display shown RPM.

Pole	Synchronous speed		Scale setting
	50HZ	60HZ	
2	3000	3600	60
4	1500	1800	30
6	1000	1200	20
8	750	900	15
10	600	720	12
12	500	600	10

<b>Maximum voltage frequency</b>
<b>CD17</b>

<b>Setting Range</b>	<b>25 ~ 400 HZ</b>
<b>USA Version</b>	<b>60 HZ</b>
<b>European Version</b>	<b>50 HZ</b>

For constant torque and constant power setting.

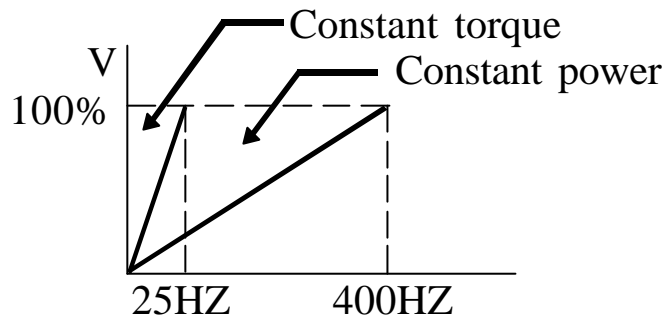

<b>V/F pattern</b>
<b>CD18</b>

<b>Setting Range</b>	<b>0 ~ 2</b>
<b>Factory Setting</b>	<b>0</b>

- 0 = Constant torque curve
- 1 = Reduce torque curve  $F^{2.0}$
- 2 = Reduce torque curve  $F^{3.0}$

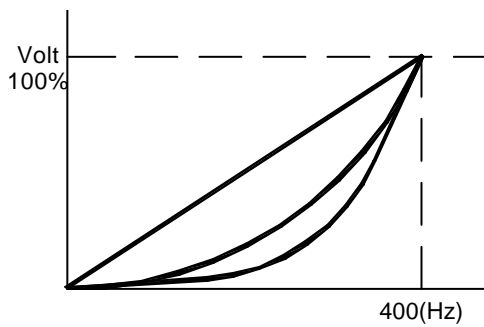

<b>DC braking time</b>
<b>CD19</b>

<b>Setting Range</b>	<b>0 ~ 25 Sec</b>
<b>Factory Setting</b>	<b>1 Sec</b>

DC brake starting at frequency under 0.5HZ.

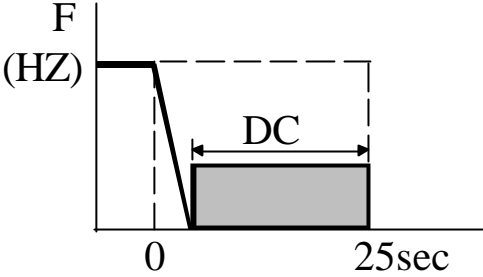

<b>DC braking power</b>
<b>CD20</b>

<b>Setting Range</b>	<b>0 ~ 250</b>
<b>Factory Setting</b>	<b>10</b>

CD20 setting DC voltage gain various braking power.

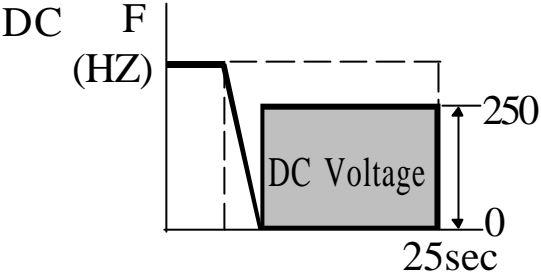

<b>Torque boost</b>
<b>CD21</b>

<b>Setting Range</b>	<b>0 ~ 25 %</b>
<b>Factory Setting</b>	<b>0 %</b>

Torque boosting is used to compensate the torque lost due to stator resistance. Over boosting will cause over current and high acoustic noise.

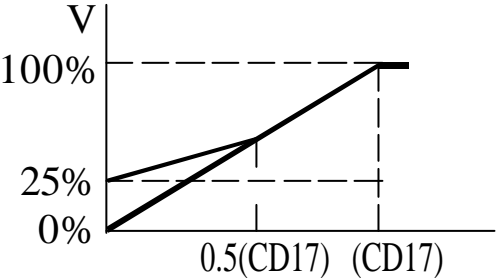

<b>Second speed setting</b>
<b>CD22</b>

<b>Setting Range</b>	<b>0 ~ 400 HZ</b>
<b>Factory Setting</b>	<b>20 (B03) / 0 (B04)</b>

<b>Third speed setting</b>
<b>CD23</b>

<b>Setting Range</b>	<b>0 ~ 400 HZ</b>
<b>Factory Setting</b>	<b>30 (B03) / 0 (B04)</b>

<b>Fourth speed setting</b>
<b>CD24</b>

<b>Setting Range</b>	<b>0 ~ 400 HZ</b>
<b>Factory Setting</b>	<b>40 (B03) / 0 (B04)</b>

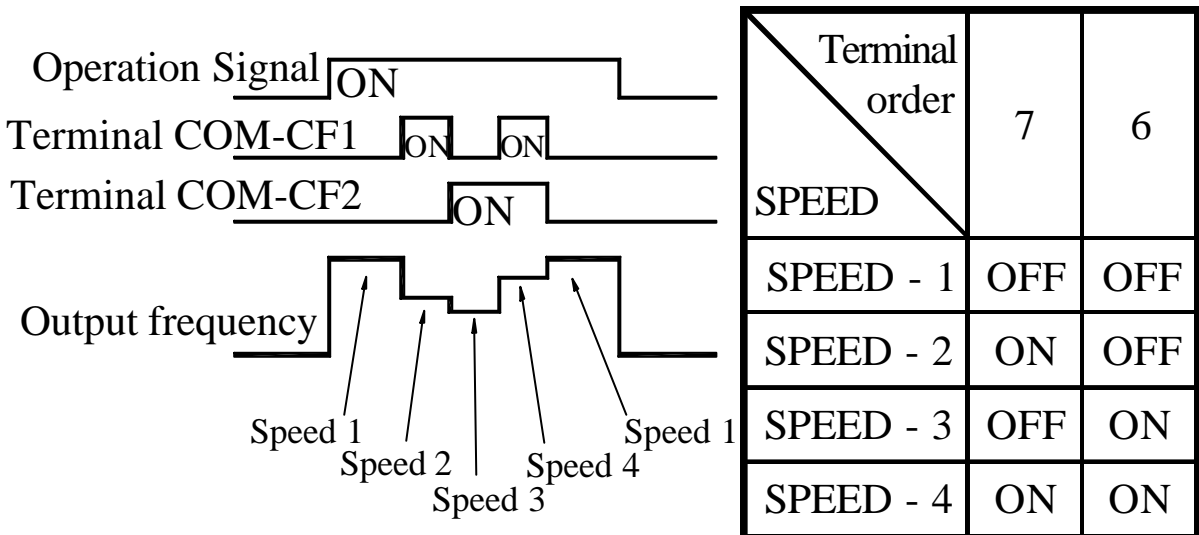

<b>Acceleration time 2</b>
<b>CD25</b>

<b>Setting Range</b>	<b>0.1 ~ 6000 SEC</b>
<b>Factory Setting</b>	<b>10 SEC</b>

<b>Deceleration time 2</b>
<b>CD26</b>

<b>Setting Range</b>	<b>0.1 ~ 6000 SEC</b>
<b>Factory Setting</b>	<b>10 SEC</b>

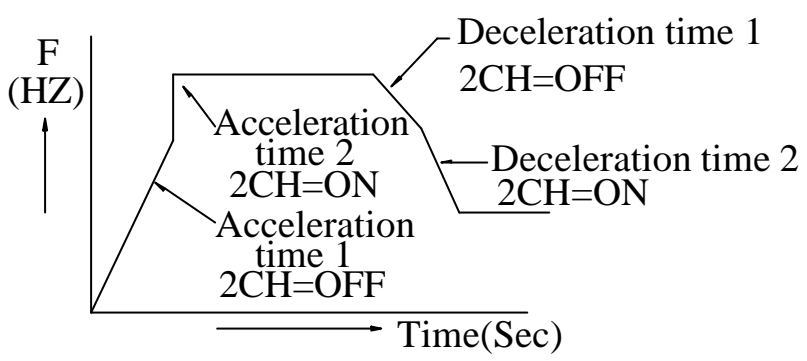

Description	2CH
Acceleration time 1	OFF
Deceleration time 1	
Acceleration time 2	ON
Deceleration time 2	

To operate inverter with 2CH function, check to see CD42 or CD43=3. 2CH command inputs from FT1 or FT2 terminal.

<b>Carrier frequency</b>
<b>CD27</b>

<b>Setting Range</b>	<b>1 ~ 16 K</b>
<b>Factory Setting</b>	<b>16 K</b>

Increase the carrier frequency would reduce motor acoustic noise but efficiency might be decreased.

Reduce the carrier frequency would reduce RF1 noise, reduce motor current, and then gain better efficiency.

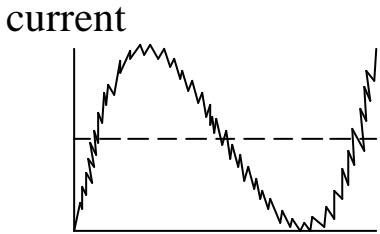

Low carrier frequency

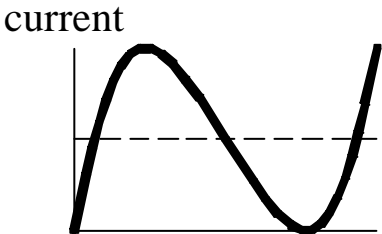

High carrier frequency

<b>Output voltage gain</b>
<b>CD28</b>

<b>Setting Range</b>	<b>50 ~ 100 %</b>
<b>Factory Setting</b>	<b>100 %</b>

Reduce output voltage for energy saving operation.  
 Setting CD44(45)=12 for FA1 (FA2) terminal control.

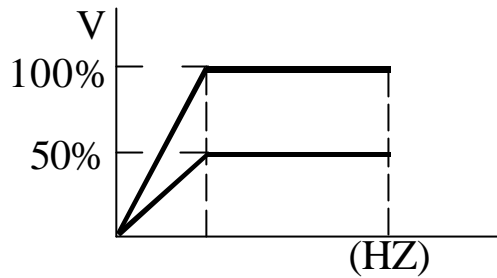

<b>Frequency jump 1</b>
<b>CD29</b>

<b>Setting Range</b>	<b>0 ~ 400 HZ</b>
<b>Factory Setting</b>	<b>0 HZ</b>

<b>Frequency jump 2</b>
<b>CD30</b>

<b>Setting Range</b>	<b>0 ~ 400 HZ</b>
<b>Factory Setting</b>	<b>0 HZ</b>

<b>Frequency jump 3</b>
<b>CD31</b>

<b>Setting Range</b>	<b>0 ~ 400 HZ</b>
<b>Factory Setting</b>	<b>0 HZ</b>

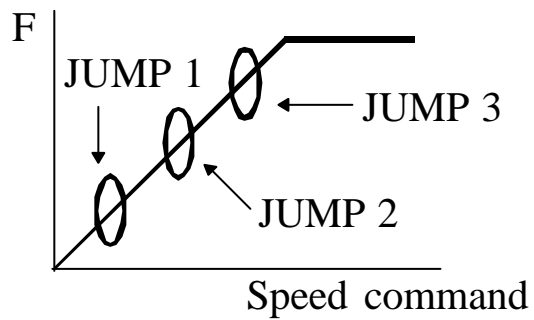

<b>Jump range</b>
<b>CD32</b>

<b>Setting Range</b>	<b>0.5 ~ 3 HZ</b>
<b>Factory Setting</b>	<b>0.5 HZ</b>

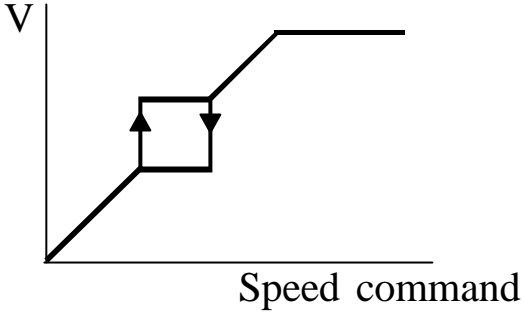

<b>Frequency reference bias</b>
<b>CD33</b>

<b>Setting Range</b>	<b>0 ~ 400 HZ</b>
<b>Factory Setting</b>	<b>0</b>

Move Frequency bias with same gradient.  
 Frequency at negative bias range, The motor can not start.

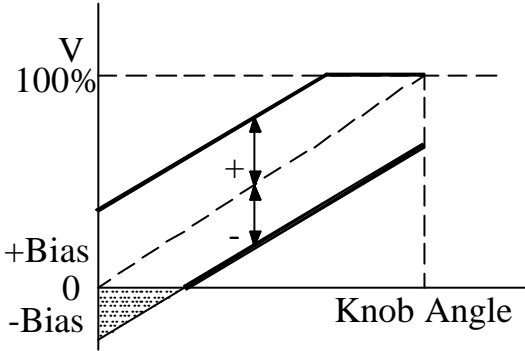

<b>Freq. ref. bias direction</b>
<b>CD34</b>

<b>Setting Range</b>	<b>0 or 1</b>
<b>Factory Setting</b>	<b>0</b>

0 = Positive “+ “  
 1 = Negative “-“  
 Polarity setting for (CD33) frequency reference bias.

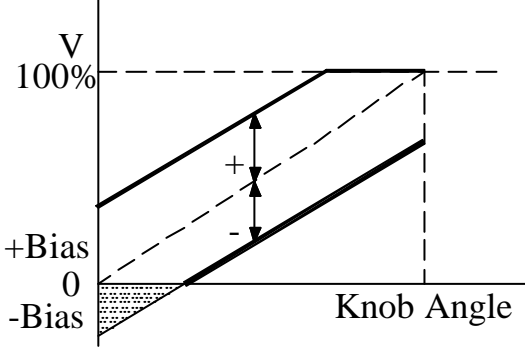

<b>Frequency gain</b>
<b>CD35</b>

<b>Setting Range</b>	<b>40 ~ 200 %</b>
<b>Factory Setting</b>	<b>100 %</b>

Application refer to example 04 at page 52.

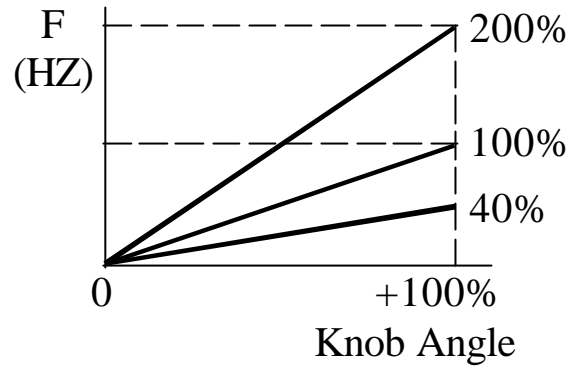

<b>The latest error record</b>
<b>CD36</b>

<b>Error record 1</b>
<b>CD37</b>

<b>Error record 2</b>
<b>CD38</b>

<b>Error record 3</b>
<b>CD39</b>

Errors record flow-chart when Error occur. The new content will shift the other contents to one higher CD code and the highest one will be dropped.



<b>Clear errors record</b>
<b>CD40</b>

<b>Setting Range</b>	<b>0 or 1</b>
<b>Factory Setting</b>	<b>0</b>

Set CD40=1 and **PROG** clear CD36 ~ CD39 Error Record the contents in CD36 ~ CD39 are “ NONE “

<b>HZ/RPM Display</b>
<b>CD41</b>

<b>Setting Range</b>	<b>0 or 1</b>
<b>Factory Setting</b>	<b>0</b>

0 = HZ Display      1 = RPM Display  
 Setting current scale CD16 for rpm display shown.

<b>FT1 Multi-Function Terminal 1</b>
<b>CD42</b>

<b>Setting Range</b>	<b>0 ~ 15</b>
<b>Factory Setting</b>	<b>0</b>

FT1 FT2	Symbol	Function description
0	-----	-----
1	JOGF	Jog operation FWD command
2	JOGR	Jog operation REV command
3	2CH	ACC/DEC time 2 command
4	FRS	Free running command
5	3 - WIRE	3 - wire sequence mode
6	CF3	5 - 8 Speed Setting Terminal
7	VF2	2nd V/F curve setting (CD56)
8		Reserved
9	OH	External over temperature command
15		Reserved

### 3 - WIRE CIRCUIT CONNECTION DIAGRAM (terminal latch function)

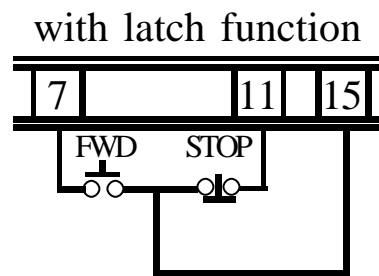
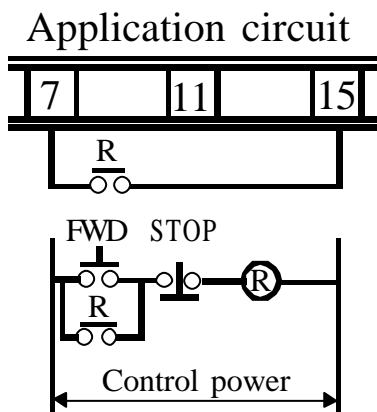
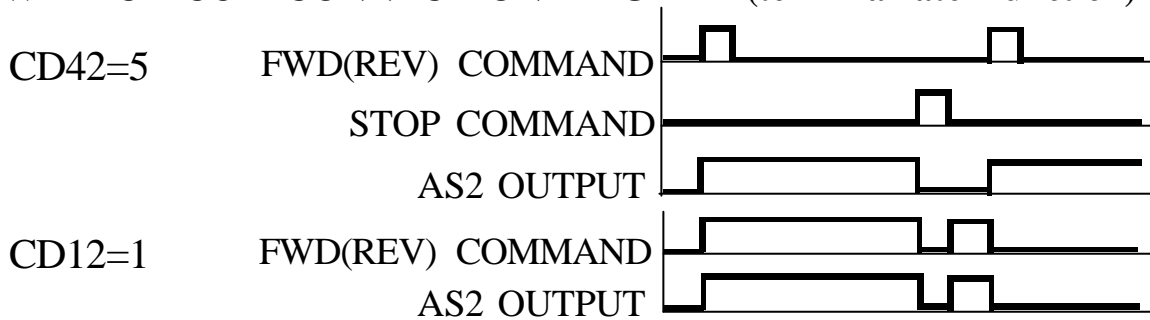

Ⓜ and CONTROL POWER not necessary  
 Remark: STOP command entry from control terminal ⑪ FT1 or ⑫ FT2, and set CD42(FT1)=5 or CD43(FT2)=5 before operation.

<b>FT2 Multi-Function Terminal 2</b>
<b>CD43</b>

<b>Setting Range</b>	<b>0 ~ 15</b>
<b>Factory Setting</b>	<b>0</b>

Refer to CD42 table.

Used for connection refer to 3-2 jumper setup (page 11).

<b>Free analog terminal 1</b>
<b>CD44</b>

<b>Setting Range</b>	<b>0 ~ 15</b>
<b>Factory Setting</b>	<b>0</b>

Refer to CD45 table.

<b>Free analog terminal 2</b>
<b>CD45</b>

<b>Setting Range</b>	<b>0 ~ 15</b>
<b>Factory Setting</b>	<b>0</b>

Setting NO. 11 to use application of example 04 (page 52).

<b>FA1 FA2</b>	<b>Function</b>	<b>Setting Range Min-----Max</b>
<b>0</b>	<b>-----</b>	<b>-----</b>
<b>1</b>	<b>Acceleration time 1</b>	<b>0 ~ CD02 Content</b>
<b>2</b>	<b>Deceleration time 1</b>	<b>0 ~ CD03 Content</b>
<b>3</b>	<b>Acceleration time 2</b>	<b>0 ~ CD25 Content</b>
<b>4</b>	<b>Deceleration time 2</b>	<b>0 ~ CD26 Content</b>
<b>5</b>	<b>Boost setting</b>	<b>0.0 ~ 25.0 %</b>
<b>6</b>	<b>DC Brake time</b>	<b>0 ~ 25 Sec</b>
<b>7</b>	<b>DC Brake Energy</b>	<b>0 ~ 250</b>
<b>8</b>	<b>Speed 2</b>	<b>F-min ~ F-max</b>
<b>9</b>	<b>Speed 3</b>	<b>F-min ~ F-max</b>
<b>10</b>	<b>Speed 4</b>	<b>F-min ~ F-max</b>
<b>11</b>	<b>Fmax</b>	<b>F-min ~ CD14 content</b>
<b>12</b>	<b>Output voltage gain</b>	<b>50% ~ 100%</b>
<b>13</b>	<b>Speed 1</b>	<b>F-min ~ F-max</b>
<b>14</b>	<b>Reserved</b>	
<b>15</b>	<b>Reserved</b>	

<b>5th speed setting</b>
<b>CD47</b>

<b>6th speed setting</b>
<b>CD48</b>

<b>7th speed setting</b>
<b>CD49</b>

<b>8th speed setting</b>
<b>CD50</b>

<b>Dynamic braking energy limit</b>
<b>CD51</b>

SPEED	CF3	CF2	CF1
1th speed setting	OFF	OFF	OFF
2th speed setting	OFF	OFF	ON
3th speed setting	OFF	ON	OFF
4th speed setting	OFF	ON	ON
5th speed setting	ON	OFF	OFF
6th speed setting	ON	OFF	ON
7th speed setting	ON	ON	OFF
8th speed setting	ON	ON	ON

For example, set 8th speed as follows :

1. CD12=1 (Terminal function)
2. CD42 or CD43=6 (Function command)  
(FT1 or FT2 → CF3)

The higher the percentage, the more braking energy.

The lower the percentage, the lower braking energy.

Description of regenerative discharge braking active period.

1. 0 ~ 100% Decel only
2. 101 ~ 200% Braking active period of  
(Decel/accel/constant frequency)
3. 201 ~ 300% Braking active period of  
(Decel/accel/constant frequency/stand-by)

<b>Version selector</b>
<b>CD52</b>

<b>Eur</b> → <b>European Version</b>
<b>USA</b> → <b>US Version</b>

Select function CD52, then use UP/Down key to select Eur/USA Version. Press **PROG** to save it. System return to the factory setting.

<b>S curve</b>
<b>CD53</b>

<b>Setting Range</b>	<b>0 ~ 7</b>
<b>Factory Setting</b>	<b>0</b>

Setting S curve non-Linear Accel/Decel Operation from 1 to 7. Setting 0 is normal operation without S curve.

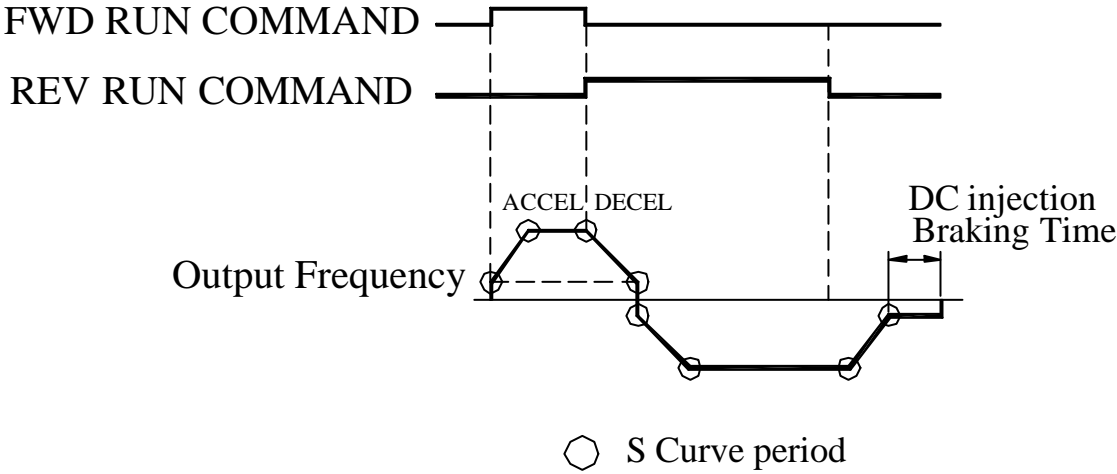
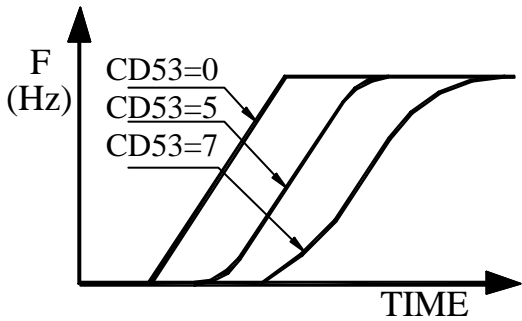

<b>4 ~ 20 mA</b>
<b>CD54</b>

<b>Setting Range</b>	<b>0 ~ 3</b>
<b>Factory Setting</b>	<b>0</b>

Set FA1 (FA2) for current signal (4 ~ 20mA). This function only effects in CD44(CD45)=8,9,10,13

- 0 : NO Current Signal Application
- 1 : Current Signal in Terminal FA1
- 2 : Current Signal in Terminal FA2
- 3 : FA1 & FA2 Current Signal Terminal

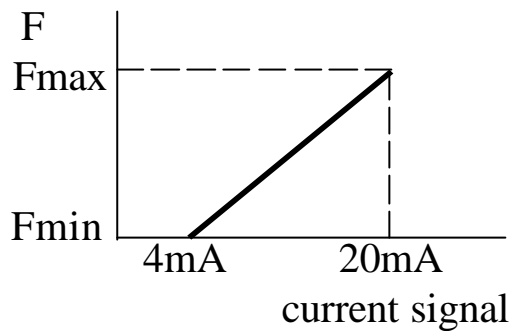

<b>Frequency arrive signal range</b>
<b>CD55</b>



<b>Setting Range</b>	<b>0% ~ 100%</b>
<b>Factory Setting</b>	<b>10%</b>

JP1 selector moves to ARR connection. If running Freq is suitable the attachment lists, the MT terminal will output ON signal.

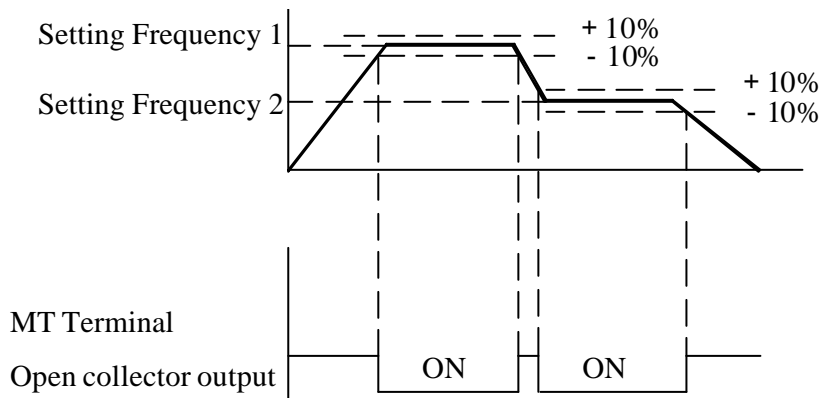
- 1.Signal output at running F. setting  $F \times (1 - CD55\%)$  for acceleration.
- 2.Signal output at running F. setting  $F \times (1 + CD55\%)$  for deceleration.



Note : When setting CD55, please follow the sequence.

1. set CD15 = 0
2. set CD55 = xx use   or  key (xx cd value)
3. set CD15 = xx (if xx > 0)

<b>2nd Maximum Voltage frequency</b>
<b>CD56</b>

<b>Setting Range</b>	<b>25 ~ 400</b>
<b>Factory Setting</b>	<b>120</b>

Set CD42(CD43)=7 define FT1(FT2) Terminal for hardware V/F curve switcher.

Open : select the 1st V/F curve preset in CD17

Close : select the 2nd V/F curve preset in CD56

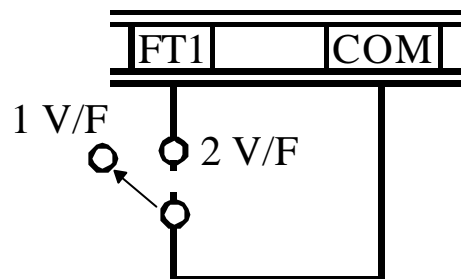
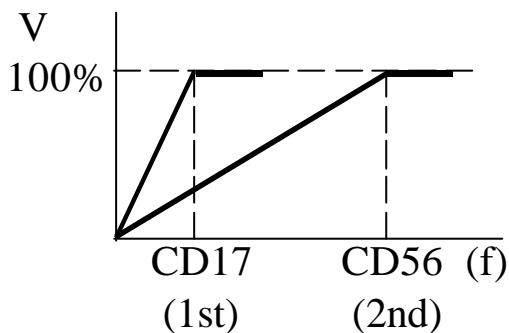

<b>No. of auto restart attempt</b>
<b>CD57</b>

<b>Setting Range</b>	<b>0 ~ 10</b>
<b>Factory Setting</b>	<b>0</b>























Inverter auto restart if power device failure Max. auto restart times are 10 within 30 min.

7-2. Operation key-in sequence

EXAMPLE : CHANGE acceleration time

Setting sequence	Display indicator	Description
		In waiting mode, the display is blinking
		Enter function mode
		Select function number 1 (parameter lock)
		Press "FUNC" again to change the parameter value
		Enable to change parameter
		Save the parameter and back to waiting mode
		Enter function mode
		Select function number 2 (acceleration time)
		Press "FUNC" again to change the parameter value
		Select the first digit
		Increase the value to 3
		Select the second digit
		Increase the value to 2
		Save CD02=12.3 and back to waiting mode

## CHANGE maximum frequency limit

Setting sequence	Display indicator	Description
		Enter function mode
 		Increase the value to 4
 		Select the second digit
		Increase the value to 1
		Press "FUNC" again to change the Maximum frequency limit
  		Select the second digit
  		Decrease the value to 9
		Save CD14=90HZ and back to waiting mode

## 8. DISPLAY ERROR CODES

### A. Inverter self-checking errors

<b>Internal protection</b>
<b>CPU</b>

Noise protection.

Self test failure protection

<b>Program check sum error</b>
<b>EP0</b>

<b>EEPROM access error</b>
<b>EEP1</b>

<b>EEPROM check-sum error</b>
<b>EEP2</b>

<b>Power device failure 1</b>
<b>PF01</b>

Power device failure during acceleration

<b>Power device failure 2</b>
<b>PF02</b>

Power device failure during constant frequency

<b>Power device failure 3</b>
<b>PF03</b>

Power device failure during deceleration (stopping)

<b>Power device failure 4</b>
<b>PF04</b>

Power device failure during stand-by

**B. Operation errors**

<b>Parameter Locked</b>
<b>OPE1</b>

To change the contents of CD02~CD52 set CD01=press  first

<b>FWD or REV only</b>
<b>OPE2</b>

Motor direction limiter.  
See function description 6.1:CD08

<b>Analog signal input only</b>
<b>OPE3</b>

Motor speed command from control terminal only.  
Input analog signal by Frequency knob  
see functions description 6.1:CD10

<b>Terminal command only</b>
<b>OPE4</b>

Accept run command from control terminal only.  
Not operation panel.  
See functions description 6.1:CD12

<b>Over range error</b>
<b>OPE5</b>

Operating error message ~ over range.

<b>Logic error warning</b>
<b>OPE6</b>

Logic error when setting.  
EXAMPLE : Setting F-min > F-max will result an error.

<b>Only changed in standby</b>
<b>OPE7</b>

The parameter can only be changed in standby mode.

<b>Read only parameter</b>
<b>OPE8</b>

The parameter created by system. Unable to be changed by user.

## **9. HARDWARE PROTECTIVE FUNCTION**

- (1) Over-current protection**
- (2) Short circuit protection**
- (3) Over-temperature protection**
  - A. U V W phase short protection**
  - B. Ground short protection**
- (4) Control supply under-voltage protection**
- (5) Power source under voltage**
- (6) Over voltage protection**

## **10. PRECAUTIONS**

### **10-1 Prior to maintenance, check the following :**

- (1) Before maintenance, be sure to turn the power off and wait until the LED digits vanish in the display. However, approx. 50 VDC still remains immediately after the display disappears, so wait a little bit longer.**
- (2) When removing or re-installing a connector, do not pull the cable.**
- (3) Take special care not to misplace the connector. Carefully note any disconnecting or poor contact. Be sure to tighten the terminals and connectors securely.**

### **10-2 Application precautions**

- (1) Before you start operation, thoroughly check for erroneous wiring or short circuits in the motor or in the wiring between your motor and the inverter. Do not ground the neutral point of the motor with a star connection.**
- (2) An inverter-driven run generates a certain amount of electromagnetic noise, as compared with that of driven directly by a commercial power supply. Thus you should be aware of such limitation when using an inverter-driven motor at a noise-sensitive site.**
- (3) Before setting the maximum frequency at 60HZ or higher, confirm that this operation range is acceptable with that of your motor.**
- (4) When you determine an appropriate inverter capacity, ensure that the rated current of the motor does not exceed the inverter' s rated current.**
- (5) Install a mold-case circuit breaker (MCCB) at the inverter' s power supply end to protect the wiring.**

# 11. TROUBLESHOOTING

Display symbol	Cause of fault message contents	Check point	Suggested remedy
No display	Discharge LED extinguished	Review the power system. Check that MCCB has been turned on or no poor contact.	Turned on or Replace MCCB
PF01	Power device failure during acceleration	The acceleration time is too short.	Increase the acceleration time
		Boost voltage too high	Reduce CD21 contents
		Check the motor is locked or the load is too heavy	Reduce the load factor
PF02	Power device failure during constant frequency operation	Check for sudden change in load	Eliminate sudden change in load
		Check that the ambient temperature is too high	Reduce the ambient temperature
		Power supply voltage is too high.	Reduce the voltage within specified range
PF03	Power device failure during deceleration	The load $GD^2$ is excessive	Set the deceleration time suitable for load $GD^2$
		Power supply voltage is too high	Reduce th voltage within specified range
PF04	Power device failure during stand-by	Check around the noise source. Power supply voltage is too high.	Remove the cause  Reduce the voltage
EEP1	EEPROM access error	Rework with previous process. Check for the same message.	Repair
EEP2	EEPROM check-sum error		

# 12. APPLICATION

## EXAMPLE 01 : Using variable resistor for multistage speed setting

### DESCRIPTION :

- CD10 = 1** ( Use frequency knob for 1st speed setting)
- CD12 = 1** ( External command)
- CD44 = 8** ( 2nd speed signal enter from FA1)
- SW1 = RUN / STOP**
- SW2 = 1st / 2nd SPEED**

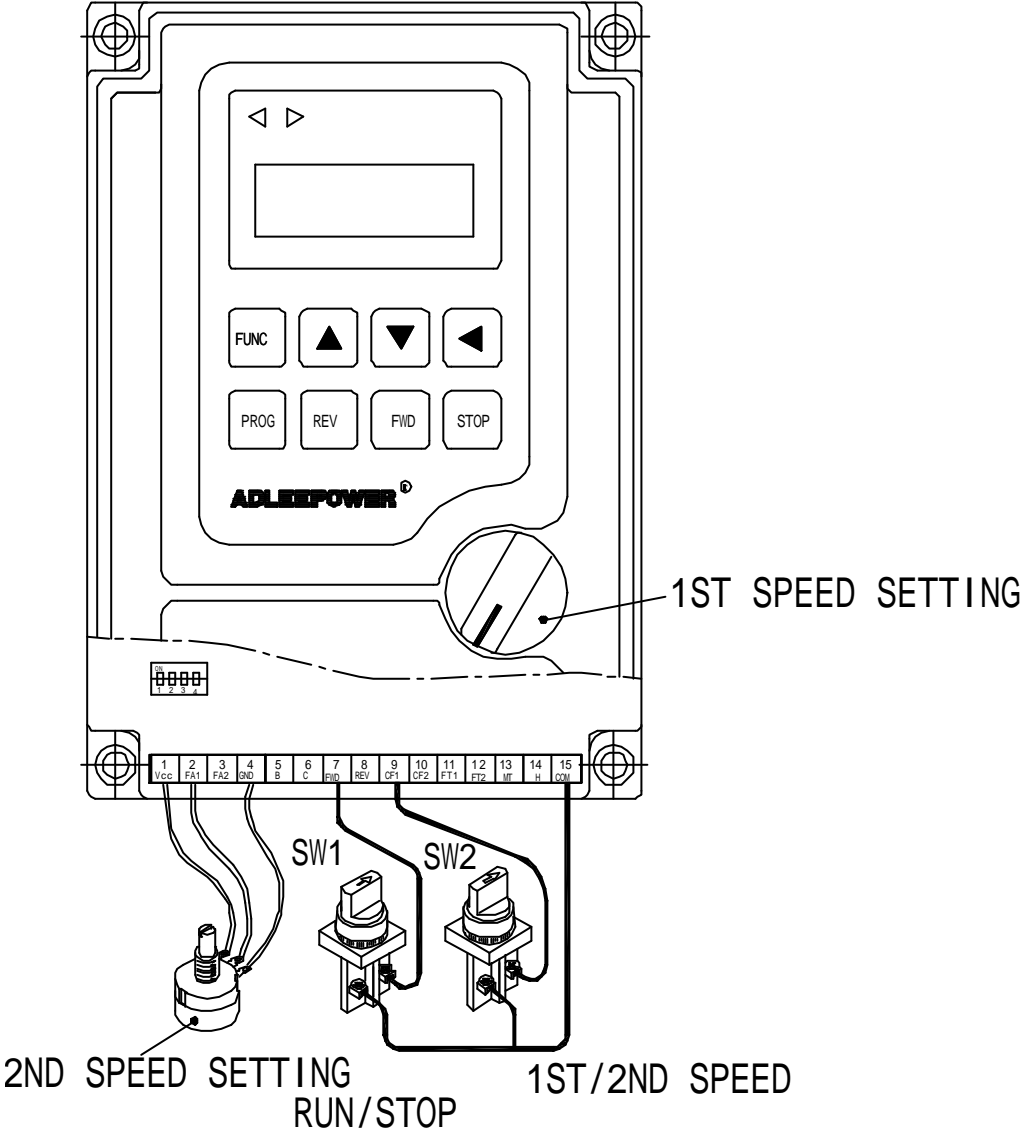

## EXAMPLE 02 : Normal / Jog operation

### DESCRIPTION :

- CD00 = Normal speed ; User setting
- CD04 = Jog speed ; User setting
- CD12 = 1 ; Terminal command (For External)
- CD42 = 1 ; Define FT1 Terminal = JOGF function
- CD43 = 2 ; Define FT2 Terminal = JOGR function

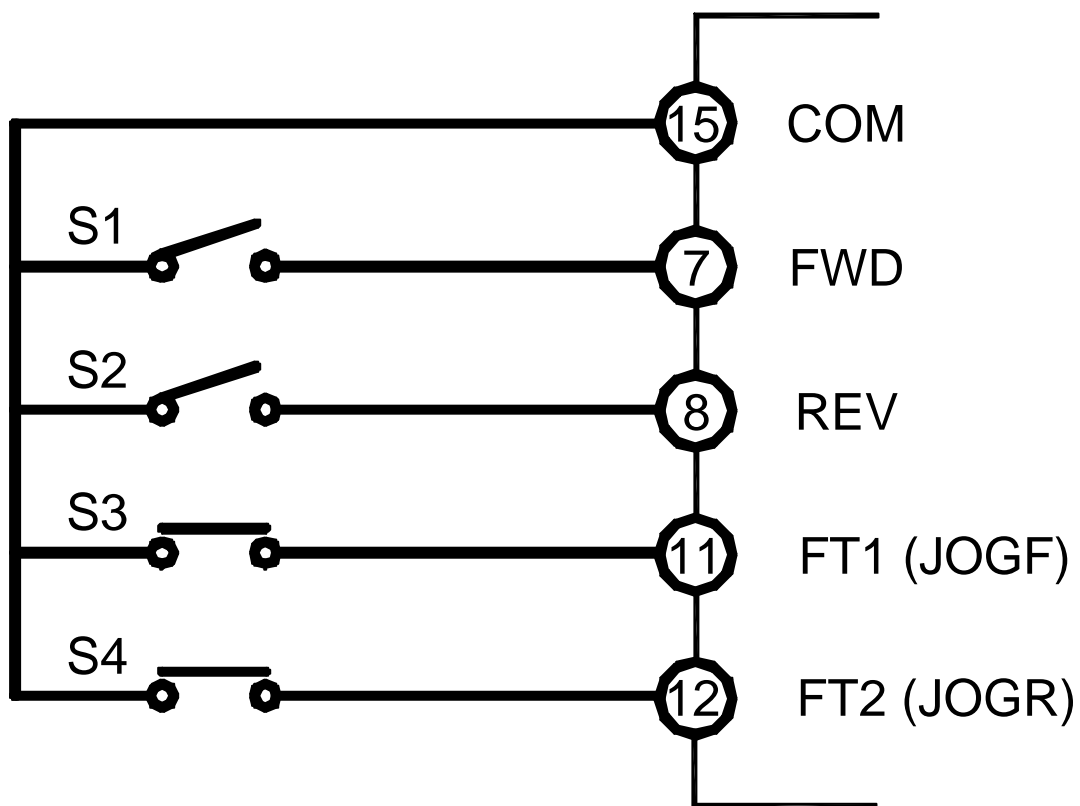

### NORMAL / JOG

- S1 = FWD SW
- S2 = REV SW
- S3 = FWD JOG SW
- S4 = REV JOG SW

**EXAMPLE 03 : Using rheostart for 3stage speed setting**

**DESCRIPTION :**

- CD12 = 1 ; Terminal command (For External)**
- CD44 = 8 ; 2nd speed signal enter from FA1**
- CD04 = 1 ; 3nd speed signal enter from FA2**

SPEED	TERMINAL		SPEED COMMAND ENTRY
	SW2	SW1	
1	OFF	OFF	FREQUENCY KNOB
2	OFF	ON	VR2
3	ON	OFF	VR3

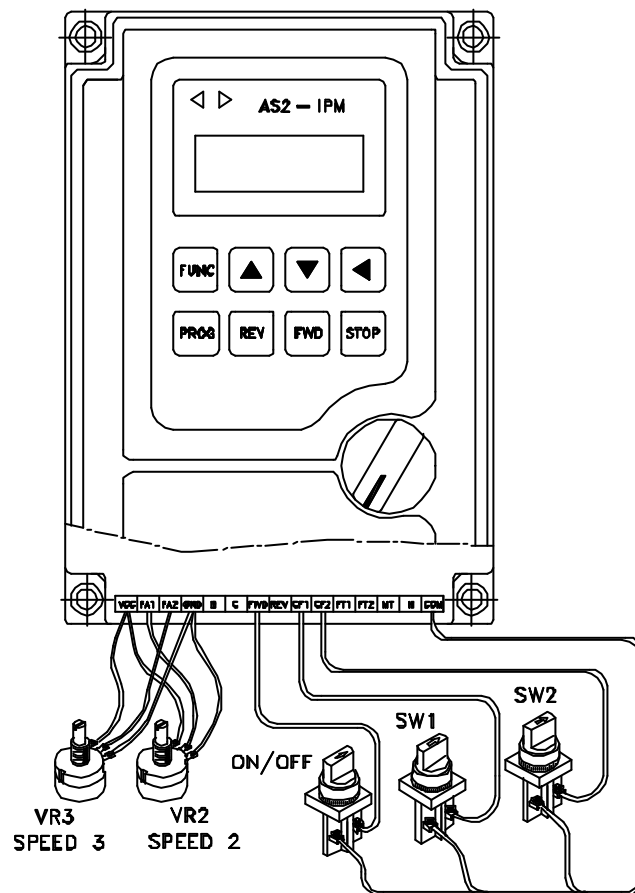

**EXAMPLE 04 : Master / slave driver system**

**DESCRIPTION : Set FA1 as 2nd speed signal input terminal.**

**Connect COM and CF1 for 2nd speed command always.**

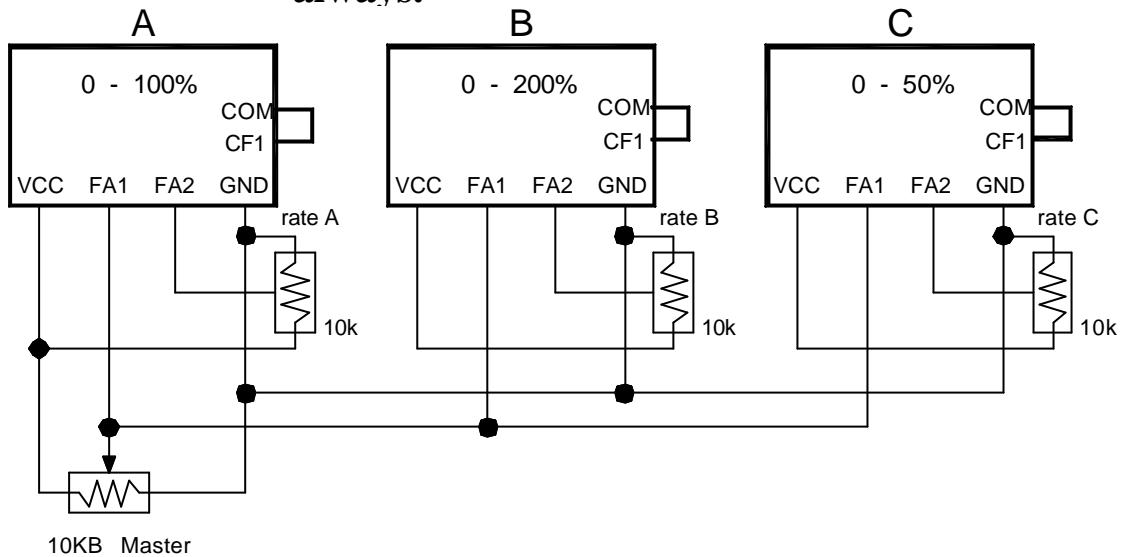

Number	A	B	C
Speed rate	0 ~ 100%	0 ~ 200%	0 ~ 50%
Function setting	CD12 = 1 CD14 = 100 CD44 = 13 CD45 = 11	CD12 = 1 CD14 = 200 CD44 = 13 CD45 = 11	CD12 = 1 CD14 = 50 CD44 = 13 CD45 = 11

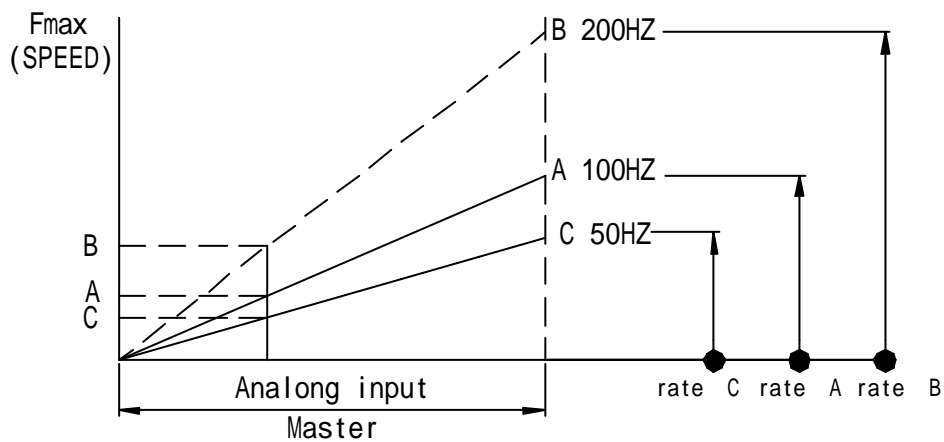

### 13. Inverter Selection

#### Inverter Capacity Check Method

Description		Related factor
Load characteristics	Load type	Friction load and weight load Liquid(viscous) load inerita load Load with power transmission and accumulation
	Load speed and torque characteristics	Constant torque Constant power Decreasing torque
	Load characteristics	Motoring Braking or overhanging load Constant load Shock load Repetitive load High-start torque Low-start torque
Operastion	Continuous operation Long-time operation at medium or low speeds Short-time operation	
Rated output	Maximum required output(instantaneous) Constant output(continuous)	
Rated rpm	Maximum rpm Rated rpm	
Power supply	Power supply transformer capacity and percentage impednace Voltage fluctuations Number of phases, less phase protection Frequency	
Deterioration of load capacity due to age	Mechanical friction, losses in wiring	
	Duty cycle modification	



## 14. APPENDIX

### A. Optional braking resistor

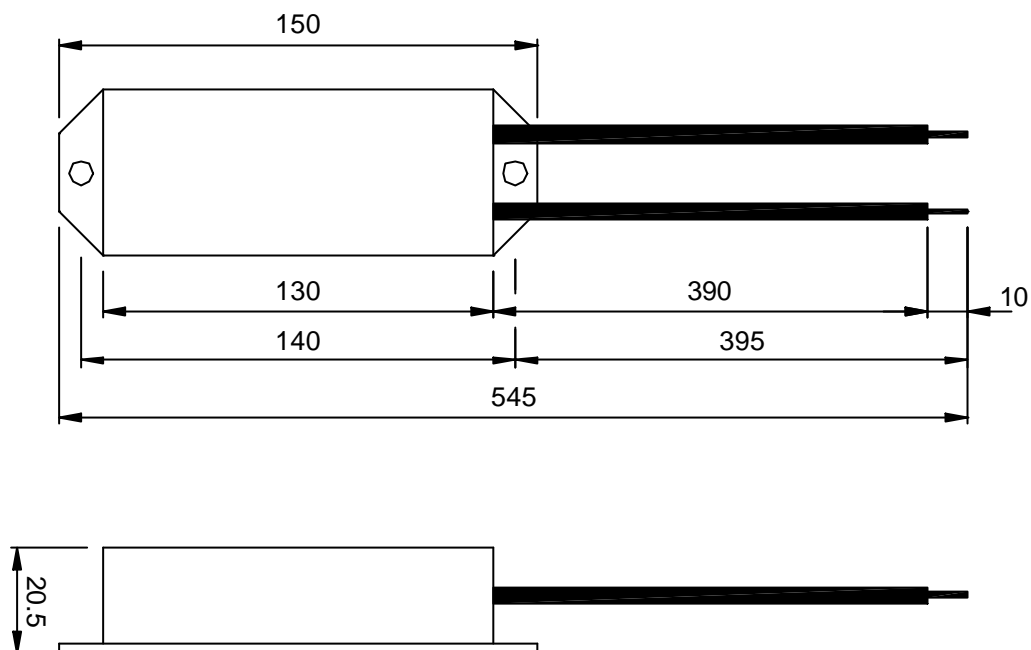

- A. The resistance of braking resistor is recommended in below list.  
The resistance must be larger than that shown in list.  
If not, may be damaged the inverter, when one want to add external braking resistor, it must remove the P,PR wiring first.
- B. Increase dynamic resistor capacity(W) when Deceleration time is setting short, or braking operation frequently.

Unit : Ohm

Model No	(3)04	(3)07	(3)15	(3)22	(3)37
AS1	60	60	--	--	--
AS2	60	60	60	60	40
AS4	200	180	180	180	160

## B. Terminals wiring diagram

### 1. SINGLE PHASE

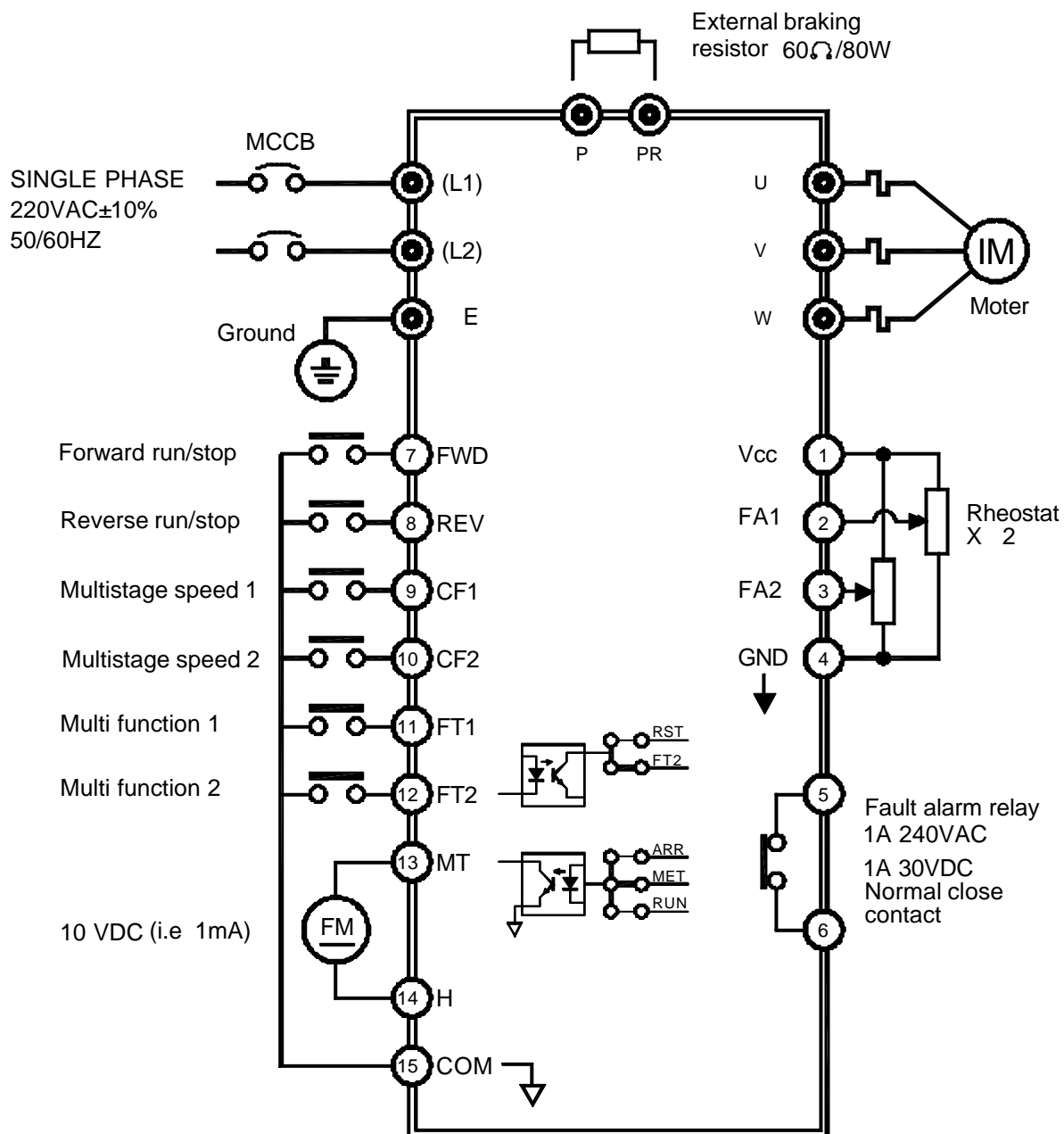

## 2. THREE PHASE

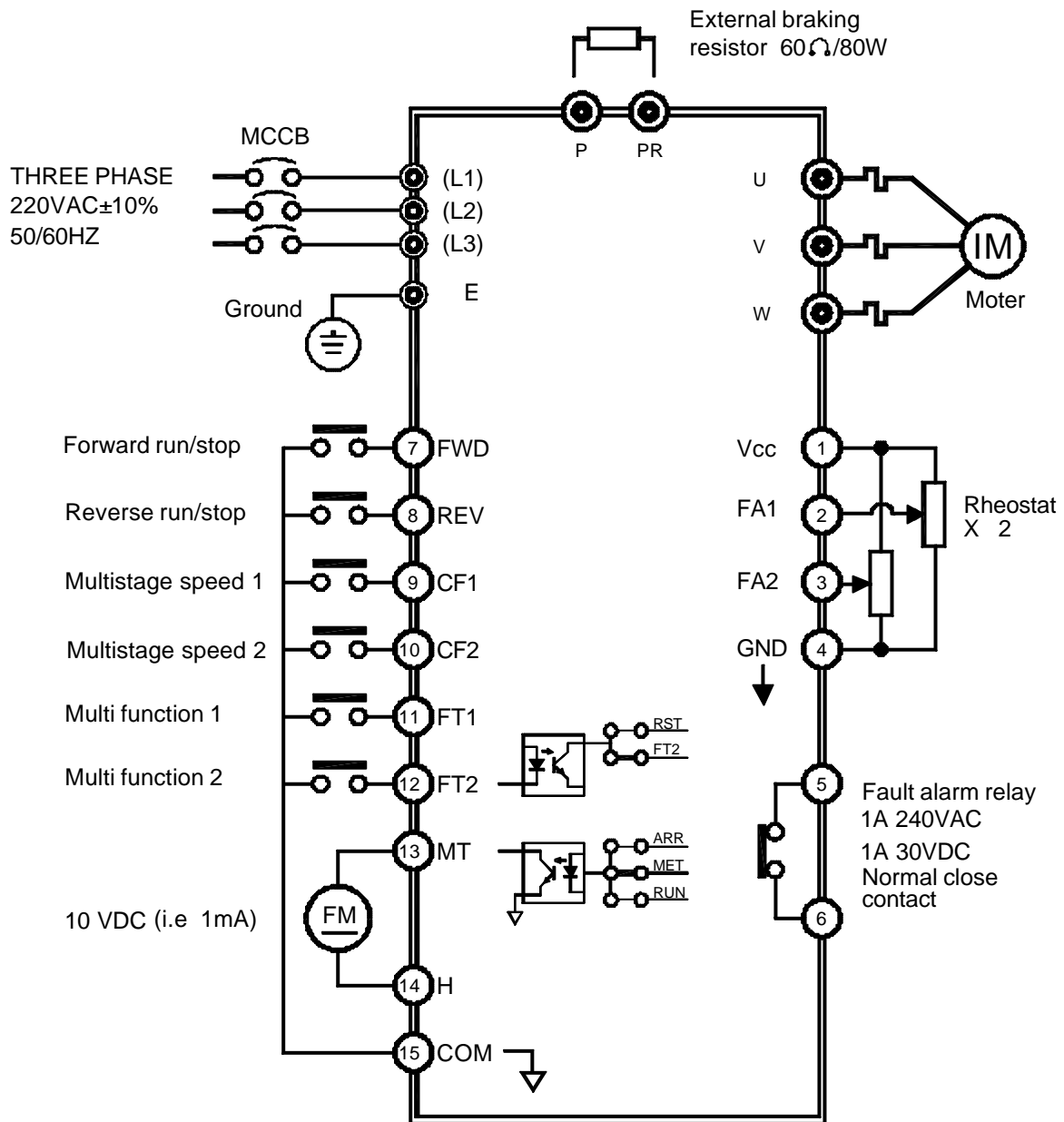

### C. F300 Remote operator

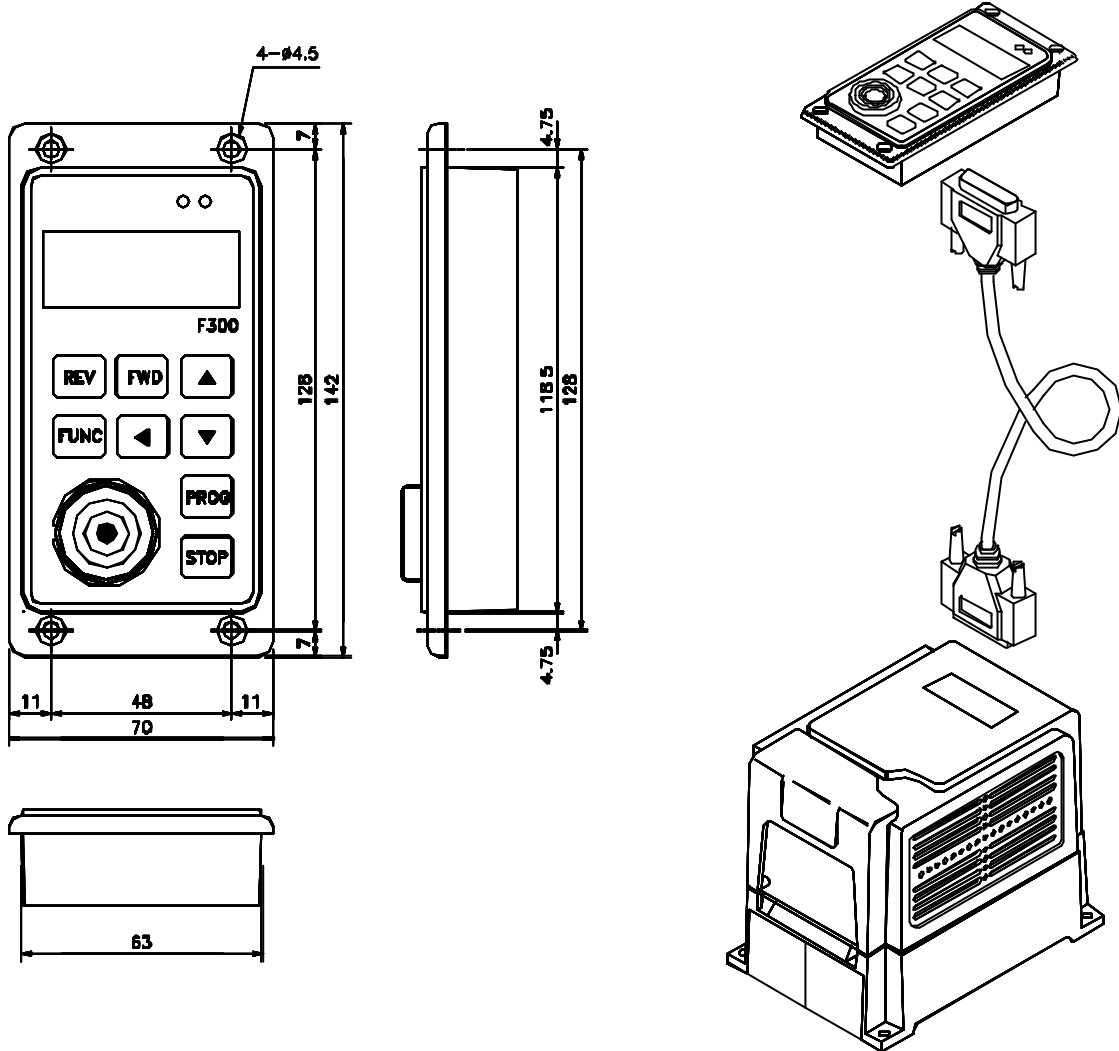

UNIT : M/M

F300 remote operator are for the remote inverters.  
Please order “R“ model inverters for remote control  
as AS2-(3)04R, AS2-(3)07R,AS2-(3)15R,  
AS2-3(22)R and mark the extension cord length.  
(1M/3M/5M)

## D. Version

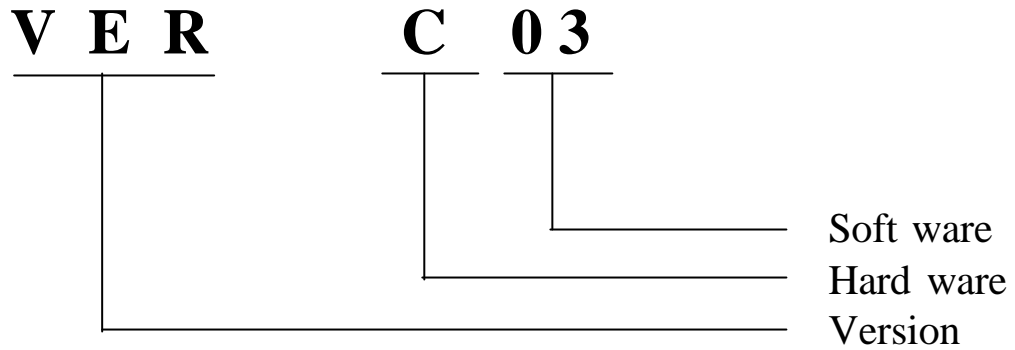

HARDWARE	DATE	NEW FUNCTIONS
Cxx	99.02	

SOFTWARE	DATE	NEW FUNCTIONS

MEMO

---

MEMO

---

MEMO

---

MEMO

---

MEMO

---

MEMO

---

INSTRUCTION MANUAL

PART NO : E-PHAA-EASB03

Model : AS series

Printed in Taiwan 2004 API. 8th Edition



**愛德利** 科技股份有限公司

**ADLEE POWERTRONIC CO., LTD.**

**Taiwan Head Office**

Tel No : 886-4-25622651

Fax No : 886-4-25628289

E-mail : webmaster@adlee.com

URL : <http://www.adlee.com>

**Canada Office**

Tel No : 1-604-3246578

E-mail : amerigo@adlee.com

**China Hong Kong Office**

Tel No : 852-24081937

E-mail : hongkongo@adlee.com

**China Shanghai Office**

Tel No : 86-21-64843529

E-mail : shanghaigo@adlee.com

**China Guang Dong Office**

Tel No : 86-757-26656498

E-mail : guandongo@adlee.com

**China Wu Han Office**

Tel No : 86-27-85712401

E-mail : wuhango@adlee.com